



TECHNICAL DOCUMENTATION

TECHNICAL DESCRIPTION

ZELIOX ZCM6

The technical description and installation instructions apply to the following Zeliox control module:

Designation
Zeliox ZCM6

Order No.
62.0150.50.0001

SEGMENTÜBERSICHT



CONSTRUCTION



AGRICULTURE/
FORESTRY



RV



UTILITY/
CARGO



CAR/LCV



AMBULANCE



PUBLIC
SAFETY



MARINE



PERSONAL
TRANSPORT



TRUCK/HCV



RAILWAY



MILITARY

1 INTRODUCTION

1.1	Concept of this documentation	5
1.2	Reference documents	5
1.3	Special text structure, presentation and pictograms	5
1.3.1	Lists	5
1.3.2	Cross references	5
1.3.3	Pictograms	5
1.4	Intended use	5
1.4.1	Range of application of the Zeliox ZCM6	5
1.4.2	Intended use of the Zeliox ZCM6	5
1.5	Non-intended use	5
1.6	Disclaimer	6
1.7	Repair	6
1.8	Target groups of this document	6
1.8.1	Instruction obligation of the target groups	6
1.8.2	Accident prevention	6
1.9	Hazard information and safety instructions for installation	6
1.10	Hazard information and safety instructions for operation	7

2 PRODUCT INFORMATION

2.1	Scope of delivery	8
2.2	Features	8
2.3	Safety symbols and markings on the product	8
2.4	Technical data	8
2.5	Dimensions	9
2.5.1	Zeliox ZCM6	9
2.6	Interface definitions	9
2.7	Indicators and switch port	9
2.7.1	Indicator lights	9
2.7.2	Switch port	9
2.7.3	DIP switch	9

3 INSTALLATION AND FIXING

3.1	Mounting the Zeliox ZCM6	10
3.2	Preparing the installation	10
3.4	Cable preparation	10
3.4.1	Single Zeliox ZCM6 wiring	11
3.4.2	Parallel Zeliox ZCM6 wiring	11
3.4.3	Cable requirements	12
3.5	Installation steps	12

4 FEATURES

4.1	Output channel	12
4.1.1	5 PWM controlled output channels, 15A each	12
4.2	Automatically turn on/off channels at a scheduled time	12

5 ZELIOX ZCM6 APP USER MANUAL

5.1	Download address	13
5.2	Bluetooth connection	13
5.3	Homepage	13
5.4	Timed automatic channel on/off function	13
5.5	Alarm page	14
5.6	Settings Page Overview	14
5.6.1	General settings	14
5.6.2	Module Settings	14
5.6.3	Channel Pairing	17
5.7	Device Information	17
5.8	Bluetooth	17

6 FAQ 18

7 SERVICE

7.1	Disassembling the Zeliox ZCM6	18
7.2	Examination	18
7.3	Cleaning	18
7.4	Transport	18
7.5	Technical support	19
7.6	EU Declaration of Conformity	19
7.7	UKCA Declaration of Conformity	19

8 ENVIRONMENT

8.1	Certification	19
8.2	Waste disposal and recycling	19
8.2.1	Disassembling the Zeliox ZCM6	19

1 Introduction

1.1 Concept of this documentation

This document supports the service company or installation company installing the Zeliox system or parts of the system and provides the user with all important information about the battery system, its components and its safe operation.



Please read first!

- The documentation is intended for the installation of the Zeliox ZCM6 module listed on the title page and is valid to the exclusion of any liability claims.
- Before installing the Zeliox ZCM6 module, be sure to read this document carefully. It contains important information that is necessary for installation.
- Be sure to observe all hazard, warning and safety instructions in this document!
- The installation work may only be carried out by an Eberspächer Zeliox service partner and by an "electrician for specific tasks" who has been trained by Eberspächer Zeliox.
- Depending on the version or revision status of the Zeliox ZCM6, differences may occur compared to this documentation. Please check this before carrying out the installation and take into account possible differences.
- Please keep this document in a safe place for future reference.

1.2 Reference documents

Troubleshooting

Contain the necessary information for troubleshooting of the Zeliox ZCM6.

1.3 Special text structure, presentation and pictograms

In this instruction, different facts are highlighted by special notations and pictograms. Refer to the following examples for their meanings and appropriate action.

1.3.1 Lists

- This dot (•) indicates a list or action step, introduced by a heading.

1.3.2 Cross references

Underlined blue text denotes a cross-reference, which can be clicked in the PDF document. The part of the document named in the text is then displayed.

1.3.3 Pictograms



DANGER!

"Danger" indicates a situation that can directly result in death or serious injuries if not avoided.

→ This arrow indicates the appropriate measures to avert the imminent danger.



WARNING!

"Warning" indicates a situation that can potentially result in death or serious injuries if not avoided.

→ This arrow indicates the appropriate measures to avert the potential danger.



CAUTION!

"Caution" indicates a situation that can potentially result in minor or slight injuries or damage to the device.

→ This arrow indicates the appropriate measures to avert the potential danger.



NOTE

This note contains recommendations for use and useful tips for the operation, installation and repair of the Zeliox ZCM6.

1.4 Intended use

1.4.1 Range of application of the Zeliox ZCM6

- Zeliox ZCM6 is a stand-alone power distribution system that connects directly to the Zeliox battery inside a utility vehicle.
- It offers the wireless management of vehicle accessories with six programmable channels and thus gives full control over interior lights, work lights, warning flashers, roof ventilators, auxiliary heating, cool boxes, track & trace, etc.
- Per channel, it digitally sets the max. amperage, time delayed shut off, permanent power, or dimmable functions.



NOTE

- The Zeliox ZCM6 must not be installed in vehicles used for the transport of dangerous goods according to ADR.

1.4.2 Intended use of the Zeliox ZCM6

- The Control Module Zeliox ZCM6 is a stand-alone, smart power distribution system that connects directly to the vehicle battery.
- It offers the wireless management of vehicle accessories with six programmable channels.
- Suitable for 12 volt or 24 volt vehicle power systems.
- 6 individual programmable and dimmable channels.
- Combination of up to 4 systems for 24 channels.



WARNING!

SAFETY INSTRUCTIONS FOR THE RANGE OF APPLICATION AND THE INTENDED USE!

The Zeliox ZCM6 must only be used and operated for the range of application stated by the manufacturer and in compliance with the operation instructions delivered with every product.

1.5 Non-intended use

Due to its functional purpose, the Zeliox ZCM6 module is not approved for the following areas of application:

- applications in medicine.
- applications in aviation.

**WARNING!**

Use, operation and deployment of the Zeliox ZCM6 outside the intended use stated by the manufacturer can cause considerable injuries to people and/or damage to machinery and property.
→ Only use the Zeliox ZCM6 for the stipulated purpose and in the approved area of use.

1.6 Disclaimer

The manufacturer is not liable for damage caused by improper use or incorrect operation. Failure to comply with the safety instructions makes the guarantee null and void and this leads to the exclusion of any liability of Eberspächer Zeliox Zeliox B.V.

1.7 Repair

Repair of the Zeliox ZCM6 module is not permitted. Failure to comply will make the warranty null and void and will result in Eberspächer Zeliox B.V. disclaiming all liability.

1.8 Target groups of this document

This document is aimed at the following target groups:

Service company

The "service company" target group includes all service companies trained by Eberspächer Zeliox that purchase Zeliox battery systems and their control units, accessories and spare parts from Eberspächer Zeliox or the aftermarket, and install, repair or service these on behalf of an end user.

Installation company

The "installation company" target group includes all companies trained by Eberspächer Zeliox that purchase Zeliox battery systems and their control units, accessories and spare parts from Eberspächer Zeliox and install, repair or service these on behalf of another company (usually the automotive / body manufacturer).

End user

The "end user" target group includes all natural persons who operate a Zeliox battery system and its components with the help of a control unit or App, regardless of whether they act as a consumer or as part of their job.

1.8.1 Instruction obligation of the target groups

Each named target group must fully comply with its instructional obligation. The instruction obligation refers to the forwarding of technical documents.

Technical documents are all documents published by Eberspächer Zeliox for the installation, operation, use, maintenance or repair of Zeliox battery systems and their control units, accessories and spare parts.

**NOTE**

- If not explicitly defined in the following, the technical documents can be passed on printed out as hard copies, on a data carrier or by internet download.
- Current technical documents for Zeliox battery systems can

be downloaded from the Eberspächer Zeliox website:
<https://www.eberspaecher-zeliox.com>

Responsibility of the installation company

The installation company must pass on the following technical documents to the company that employs them, and it in turn is obliged to pass on the documents to the end user:

- Technical description
- Operating instructions

Responsibility of the service company

The service company must pass on the following technical documents to the end user, even if they employ a subcontractor:

- Technical description
- Operating instructions

**NOTE**

- The named target groups must ensure that the operating instructions produced by the manufacturer for the product are made available to the end user in printed form and in their own national language.
- If necessary this can be a short form of the detailed operating instructions, which are additionally enclosed with the product on a data carrier or are available to download from the internet: www.eberspaecher.com

1.8.2 Accident prevention

Observe the general accident prevention regulations and the relevant workshop and operating safety instructions.

1.9 Hazard information and safety instructions for installation

The installation work may only be carried out by an Eberspächer Zeliox service partner and by an "electrician for specific tasks" who has been trained by Eberspächer Zeliox.

**NOTE**

- The manufacturer does not assume any responsibility caused by violation of general safety operation requirements or violation of safety standards for design, production and use of equipment.
- The manufacturer is not liable for damage caused by improper installation or maintenance.
- Failure to comply with the installation and maintenance specifications will void the warranty and result in Eberspächer Zeliox B.V. disclaiming all liability.
- All deviations from the safety requirements for installation are to be agreed with the manufacturer in writing before they are implemented.

**DANGER!****RISK OF INJURY, FIRE AND POISONING!**

- Disconnect the vehicle battery before starting any work.
- Do not install the Zeliox ZCM6 control module and its components if they are damaged.

- The Zeliox ZCM6 control module must only be installed if it is completely undamaged and only under the conditions specified in this document.
- Do not connect Zeliox ZCM6 components with reversed polarity.
- Components that are not correctly earthed can lead to dangerous situations.
- Ground the battery before starting installation work.
- Cables that are too small can overheat and cause injury and damage to property.
- Always use cables with sufficient dimensions.

! CAUTION!

GENERAL SAFETY PRECAUTIONS

- It is strictly forbidden to put the product in water or fire to avoid explosion or other dangers.
- Please do not stab, hit, trample or strike the product in any other way.
- Avoid direct sunlight.
- Please do not remove the product from the original packaging before use.
- The product needs to be installed in a dry and clean environment.
- During use, when the system needs to be moved or rewired, the power must be completely cut off and the system must be completely shut down, otherwise there will be a risk of electric shock.
- In order to avoid fire and electric shock, please ensure that all cables have good electrical characteristics and suitable wire diameter; it is forbidden to use damaged or too small cables.
- When encountering a fire, please use a dry powder fire extinguisher to extinguish the fire. The use of a liquid fire extinguisher may cause secondary hazards.

! CAUTION!

SAFETY ADVICE FOR THE INSTALLATION!

- Only remove the components of the Zeliox ZCM6 control module from their original packaging immediately before use.
- When connecting several control modules in series or in parallel, ensure that all modules are the same in terms of brand, type, age, capacity and charge status.
- Observe the plus (+) and minus (-) markings on the control module and ensure correct electrical connection.
- Install the components of the Zeliox ZCM6 control module so that they do not move back and forth under normal operating conditions.
- Install the Zeliox ZCM6 control module in an area of the vehicle that is protected from dirt and water.
- Do not use batteries from different manufacturers, with different capacities, sizes or types together in a Zeliox system.
- Mark the year of initial commissioning on the factory nameplate.
- The Zeliox battery system may only be installed, maintained or dismantled by a service partner authorised by the manufacturer in accordance with the specifications in this documentation and any special installation recommendations,

and must be disposed of, recycled or reconditioned in a professional manner.

- The following measures are not permitted:
 - Modifications to components
 - Use of third-party parts not approved by the manufacturer
 - Deviations from legal, safety and/or function-related specifications made in this document with regard to installation and/or operation. This applies in particular to electrical wiring.
- Only use original accessories for installation.
- When performing electric welding work on the vehicle, disconnect the positive terminal cable from the battery and connect it to ground to protect the control unit.
- Replace defective fuses only with fuses of the specified fuse rating.

i NOTE

- Any deviations from the safety requirements for installation must be agreed in writing with the manufacturer prior to implementation.

1.10 Hazard information and safety instructions for operation

i NOTE

Some of the information in this chapter also applies to chapter 1.9.10. Therefore, it should also be taken into account during installation.

! VORSICHT!

SAFETY ADVICE FOR THE OPERATION!

- Keep Zeliox ZCM6 clean and dry.
- Do not expose Zeliox ZCM6 to fire, water or solvents.
- Protect Zeliox ZCM6 from water, dust and contamination.
- Always operate Zeliox ZCM6 within the maximum permissible technical specifications.
- Remove and recycle Zeliox ZCM6 properly when no longer needed.
- Repairs to the components of the Zeliox battery system are not permitted. They will invalidate the type approval of the battery system and, in the case of motor vehicles, may invalidate the vehicle's operating licence.
- The installation space for the components of the Zeliox ZCM6 control module is not a storage space and must remain clear. In particular, do not store or transport fuel reserve cans, oil cans, spray cans, gas cartridges and other hazardous materials, fire extinguishers, cleaning rags, clothing, paper, etc. on or next to the components of the Zeliox ZCM6 control module.

i NOTE

Any deviations from the safety requirements for operation must be agreed in writing with the manufacturer prior to implementation.

2 Product information

2.1 Scope of delivery

Designation	Quantity
Zeliox ZCM6 module	1
Power output cables with connectors, 250 mm, 13 AWG	1
Remote switch cable	1
Wireless switch panel – PICO, 72 x 72 x 11.5 mm incl. 2 x CR 2032 button cell	2
Wireless panel button stickers, 40 pcs.	1
Zeliox ZCM6 screws, 4 x 20 mm	4

2.2 Features

- Maximum DC load of 76A in total
- Overvoltage / undervoltage protection function
- 6 independently controlled output channels
- Output channels support parallel connection: When parameters match, a load can be loaded by connecting two output channels in parallel.
- Over-current, under-current, short-circuit protection for a single channel
- Intelligent monitoring by built-in current sampling unit. It monitors the real time power consumption of each load. Combined with the independently designed intelligent control strategy, it can achieve energy-saving, efficient and intelligent power control, and real-time statistics of load power consumption.
- Up to 4 Zeliox ZCM6 modules in parallel
- Wireless switch panel PICO II connection
- Mobile App support by Bluetooth

2.3 Safety symbols and markings on the product

NOTE

The safety symbols and markings are intended to ensure safe operation of the battery. They must never be removed or made illegible.



Observe instructions



WEEE Marking: Dispose of the battery in accordance with local, state and federal laws and regulations. Batteries can be returned to the manufacturer. Do not mix with other (industrial) waste.



This product or parts of this product can be recycled.



CE Marking



UKCA Marking

2.4 Technical data

Model	Zeliox ZCM6	
Rated input voltage	V dc	12/24
Input voltage range	V dc	10 ... 16 / 21 ... 30
Maximum input current	A	76
Maximum output current of a single channel	A	15*5 & 25*1
Maximum output current in total	A	76
Standby power consumption	mA	≤5
Communication		BLE, RF
Parallel connection	Units	Max 4
Wireless switch	PICO	Max 10
Protection		
Input overvoltage protection	V dc	16 / 30
Input undervoltage protection	V dc	11 / 21
Output short circuit protection		Yes
Output overcurrent protection		Yes
Output undercurrent protection		Yes
Input overcurrent protection		Yes
Internal over temperature protection		Yes
Others		
Storage temperature	°C	-40 ... 85
Operating temperature	°C	-20 ... 60
IP rating	IP	20
Dimensions	mm	252 x 161 x 47 (LxWxH)
Product weight	kg	0.87
Certification		CE, UKCA, E-mark

Table 1: Technical data

2.5 Dimensions

2.5.1 Zeliox ZCM6

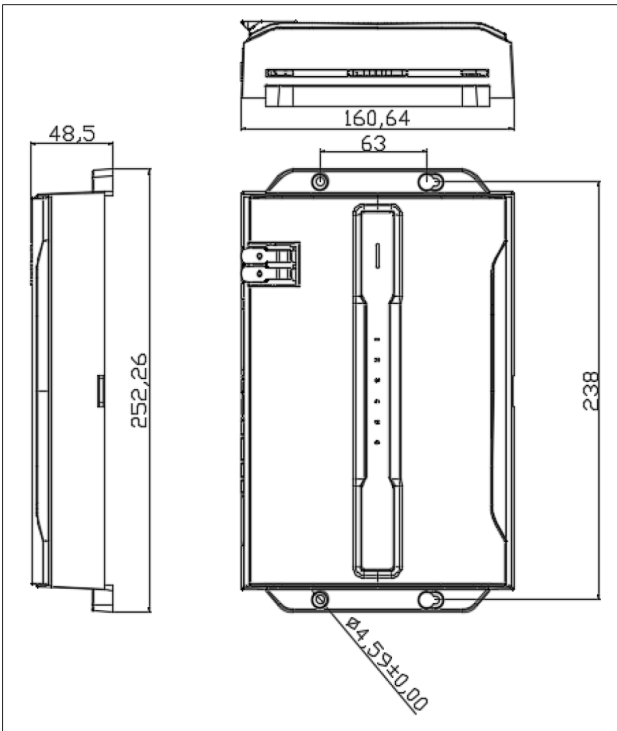
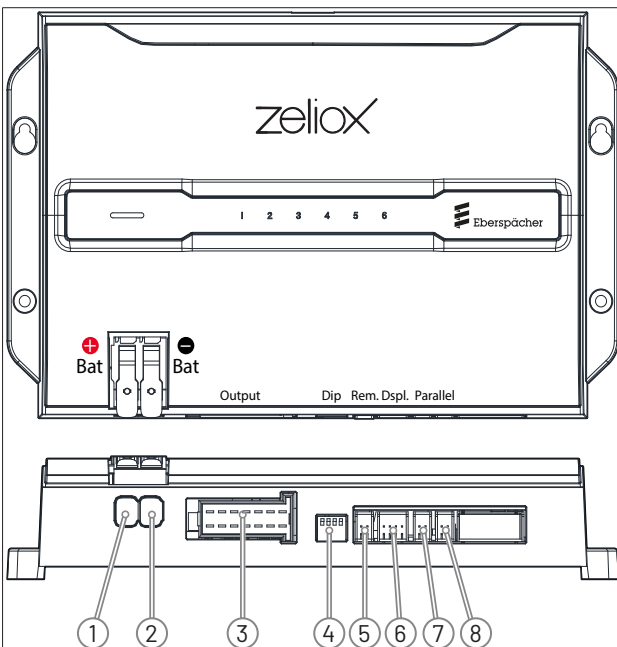

Figure 1: Dimensions

2.6 Interface definitions



No.	Terminal Definition	Polarity	Note
1	BAT+	12V/24V Power Input_Positive	
2	BAT-	12V/24V Power Input_Negative	
3	Output	Output connector	6 Channels

4	DIP	DIP switch	
5	Remote	2 PINs for remote switch; 1 PIN for D+ input detect	
6	Display	Display interface	Communication with the system
7	Parallel 1	Parallel	Parallel communication cable, can be connected to 1 or 2
8	Parallel 2	communication interface	

Table 2: Interface Definitions

2.7 Indicators and switch port

2.7.1 Indicator lights

The Zeliox ZCM6 has 7 indicator lights on the panel, which are:

1 Power Indicator

Status	Colour	Description
Run	Green	Flashing: Auxiliary source is normal, system is initializing
		Solid on: Working
Protect	Red	Flashing: Alarm
		Solid on: Protection and shut down output

2 Output channel (1-6) indicators

Status	Colour	Description
Run	White	Solid on: Working
Protect	Red	Solid on: Protection and shut down output

2.7.2 Switch port

- This product has a On/Off Switch dry contact, which can be used to control the power on and off of the entire device.
- When the On/Off Switch dry contact is engaged, it is in the power-on state.
- Otherwise it is in the power-off state.

2.7.3 DIP switch

- If you use more than one Zeliox ZCM6, please set the parallel address in advance through the DIP switch before powering on.

DIP Switch			
Pin 1	Pin 2	Parallel address	Description
Off	Off	1	Master
Off	On	2	Slave 1
On	Off	3	Slave 2
On	On	4	Slave 3

Table 3: Parallel communication address settings and instructions

DIP Switch		BLEON/OFF
Pin 3		Description
Off		BLE Off
On		BLE On

Table 4: BLE ON/OFF setting

3 Installation and Fixing

3.1 Mounting the Zeliox ZCM6

i NOTE

- Before starting installation work, ensure that you have the latest version of these installation instructions. They are available for download from the Eberspächer Zeliox portal: <https://www.eberspaecher-zeliox.com>
- Before starting installation work, read and follow all hazard, warning and safety instructions in this document.
- Switch off all power sources in the vehicle or work in such a way that existing power sources are not affected.
- Before use, the module must be effectively fixed. It cannot be fixed upside down. The fixing screws should be 4 x 20 mm.

- > Mount the Zeliox ZCM6 on a flat and stable surface using the 4 mounting screws (included).

3.2 Preparing the installation

i NOTE

- After unpacking, please check that the Zeliox ZCM6 has not been damaged during transportation and that all accessories are included.
- Zeliox ZCM6 an seinem Montageplatz weder aus der Waag-rechten neigen noch hochkant montieren. Die Normallage des Moduls am Montageplatz muss bei ebener Fahrzeugstel-lung eben sein.
- Vor dem Einbringen der Befestigungsbohrungen kontrollie-ren, dass keine darunter liegenden Fahrzeugkomponenten verdrängt oder beschädigt werden.

- > Check whether the input voltage matches the Zeliox ZCM6. If it does not match, do not use it, otherwise it may cause damage to the Zeliox ZCM6. If you are unclear, please consult the sup-plier or the manufacturer directly.
- > Check that the wiring is secure and ensure that there is no short circuit.
- > Check whether the input wiring is correct, and then connect the power supply.
- > Check whether Zeliox ZCM6 is installed stably and firmly.
- > Confirm the above items are correct before turning on the Zeliox ZCM6.

3.3 Installation space requirements

The controller must have adequate room on all sides for air flow. Refer to the sketch for minimum spacing requirements.

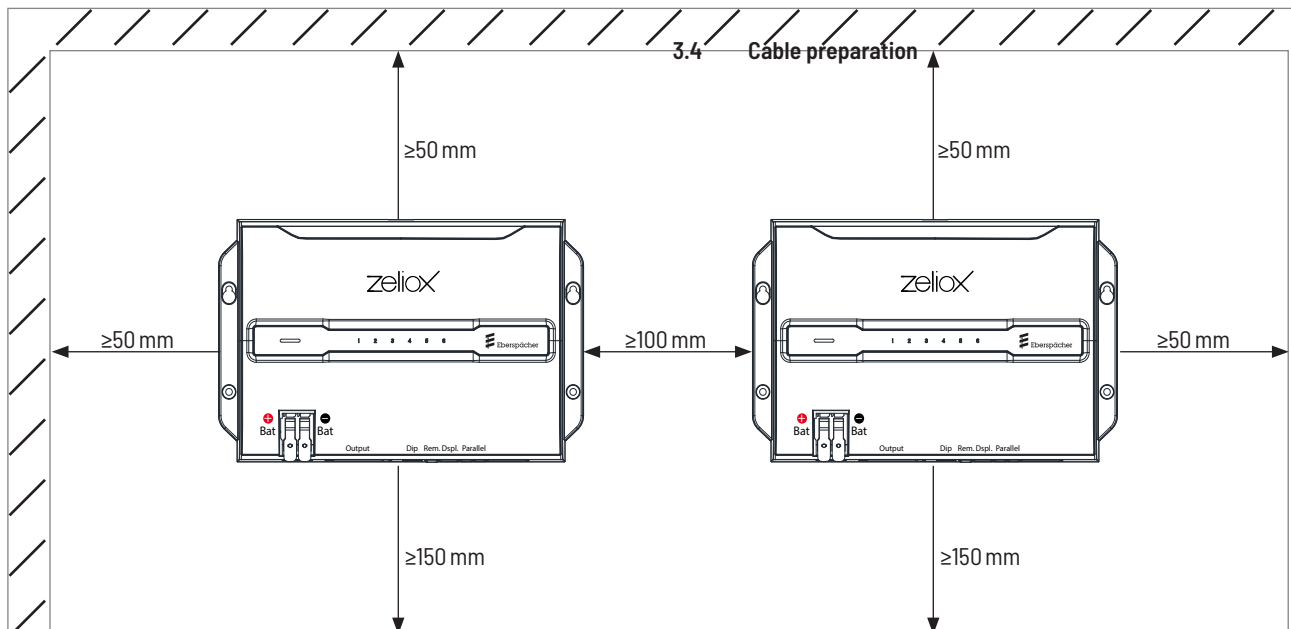

Figure 2: Space requirements

3.4.1 Single Zeliox ZCM6 wiring

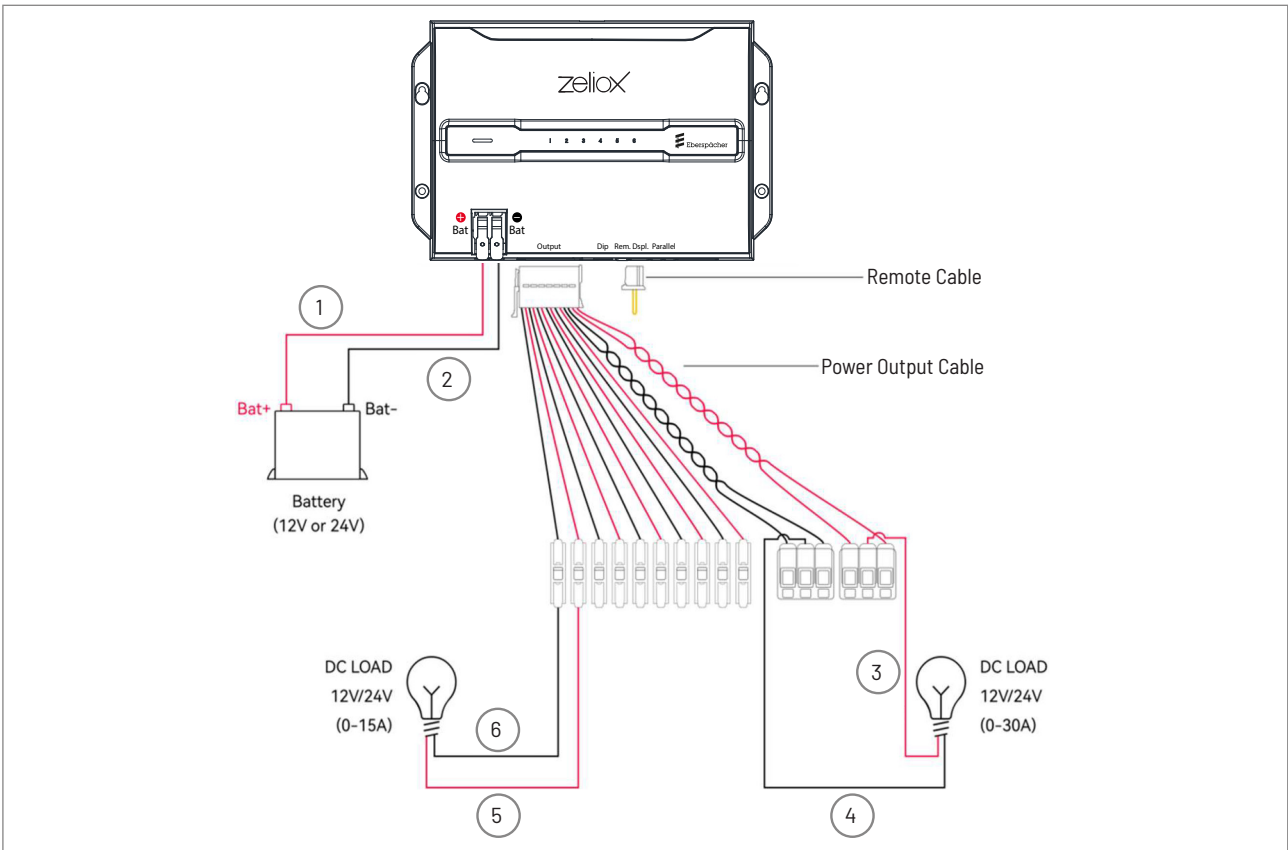

Figure 3: Single wiring

3.4.2 Parallel Zeliox ZCM6 wiring

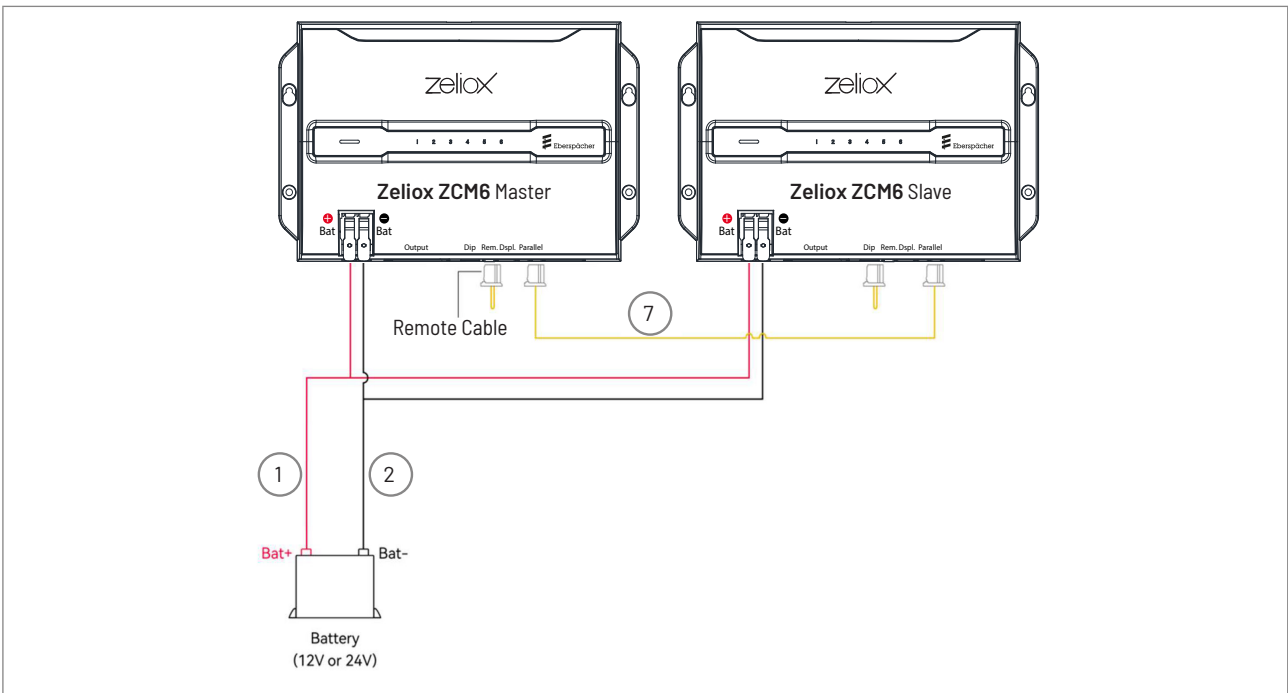

Figure 4: Parallel wiring

3.4.3 Cable requirements

No.	Recomm. wire diameter	Recomm. length	Recomm. colour	Recomm. end stripping length	Remark
①	16 mm ²	≤3 m	Red	18 - 20 mm	Parallel comm. cable (option)
②			Black		
③	6 mm ²	≤10 m	Red	9 - 10 mm	
④			Black		
⑤			Red	12 - 14 mm	
⑥			Black		
⑦					

Table 5: Cable requirements

3.5 Installation steps

Perform the following steps to connect the cables.

- > Select the appropriate wire according to [Table 5](#), make sure the input power is shut down and the Zeliox ZCM6 "Remote" port is not connected before wiring.
- > Remove the dust cap from the input terminal, connect BAT- to battery negative terminal, and connect BAT+ to battery positive terminal. Please see [Figure 3](#).

i NOTE

- Be sure to check the input polarity.
- Reversing it will damage the device!

- > Connect Output- to DC Load-, and connect Output+ to DC Load+ Please see [Figure 3](#).
- > Make sure the wire is connected correctly and reliably.
- > After the wiring connection, connect the matching "Remote Cable" to the Zeliox ZCM6 "Remote" port, turn on the input power, and the Zeliox ZCM6 will be turned on.
- > Pair the wireless switch panel PICO (please refer to the APP manual). After the PICO is paired, please stick the corresponding sticker on the PICO.
- > If you need to connect more than one Zeliox ZCM6 in parallel, please contact the dealer to purchase the parallel communication cable and connect it to the "Parallel" port of the Zeliox ZCM6 units. Please set the parallel address in advance through the DIP switch before powering on.

4 Features

4.1 Output channel

4.1.1 5 PWM controlled output channels, 15A each

- 1 Output-1 and output-2 can be connected in parallel to form a 30A channel
- 2 Output-3 and output-4 can be connected in parallel to form a 30A channel
- 3 Output-5 cannot be used in parallel

4.2 Automatically turn on/off channels at a scheduled time

- Users can set the channel to automatically ON or OFF according to actual needs.
- Users can customize the Zeliox ZCM6 channel switch mode, which are, Manual (default), AUTO OFF, AUTO ON.
- When the channel is set to automatic mode, the specified channel switch will automatically turn on or off within the set time, and the channel can also be manually turned on or off in advance.

5 Zeliox ZCM6 APP User Manual

5.1 Download address

You can monitor, control and set the Zeliox ZCM6 by a Bluetooth App.

NOTE

- For further information please download the Zeliox ZCM6 App in a common App store.
- The Zeliox ZCM6 App is available for Android and iOS.
- The screen images of the App in this document may differ from the actual images.

> Please scan the appropriate QR Code shown below to search the Zeliox ZCM6 App and to start the download process.



Google Play Store



iOS App Store

- Information on the latest updates, improvements and fixed problems can be found in the App Store as well.

5.2 Bluetooth connection

- > Please leave the Zeliox ZCM6 powered up and Dip Switch 3 ON (Bluetooth DTU enabled by default).
- > Turn on your smartphone's Bluetooth and open the Zeliox ZCM6 APP.
- > App connects with Zeliox ZCM6 Bluetooth for the first time, you need to enter the passcode.
- > The default passcode is 0000 (can be changed by the connected user),

NOTE

If the passcode is forgotten or lost, you can check the serial number of the Zeliox ZCM6 machine nameplate, and the Bluetooth passcode is the last 4 digits of the serial number.

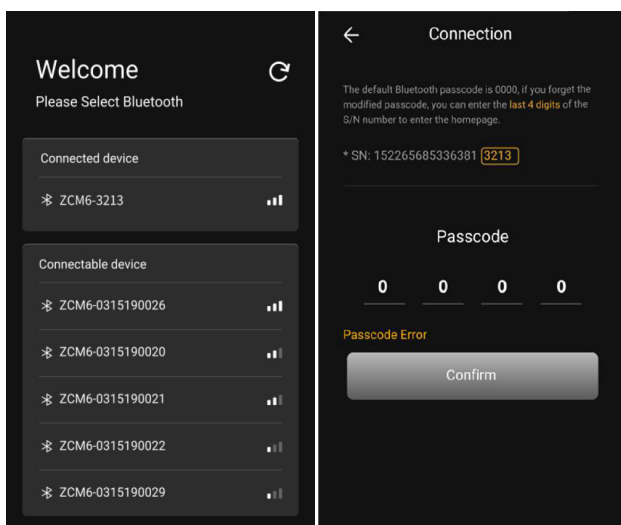

Figure 5: App connects for the first time to Bluetooth

5.3 Homepage

- Entering the App homepage, you can control each of the channel outputs (controllable load) by one click.
- A lit square button means the current output channel is switched on. When the square button is dark, it means the current output channel is switched off.
- Users can view the powering load of each channel and count the total output power in real time. Load page is divided into controllable load page and constant power load page. Constant power load type is uncontrollable. By default, Constant power load channel will be on when Zeliox ZCM6 is switched on.



Figure 6: Controllable load interface and constant load interface

- If the user sets the load type of a channel to PWM Dimming Controlled Load, a dimming icon will appear on the upper right corner of the square button, and a long press on any position of the square button will bring up the dimming button, which can be infinitely dimmed freely.

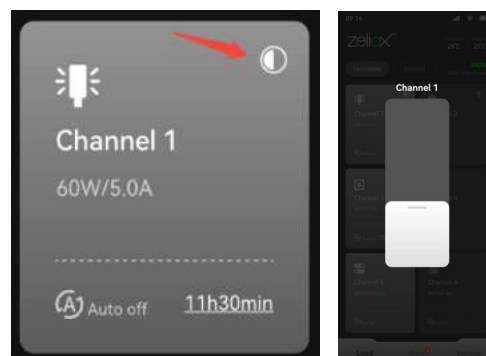

Figure 7: PWM dimming controlled load

5.4 Timed automatic channel on/off function

- Users can set the channel to turn on or off automatically at regular intervals according to actual needs, providing users with rich usage scenarios.
- Users can switch the channel switching mode by clicking the

lower left of the square button, which is divided into:

- Manual (default)
- Auto OFF
- Auto ON
- Click the time in the lower right corner to set the channel timing.
- When a channel is set to Auto mode, the specified channel switch will automatically turn on or off at a customized time, or you can manually turn the channel on or off in advance.

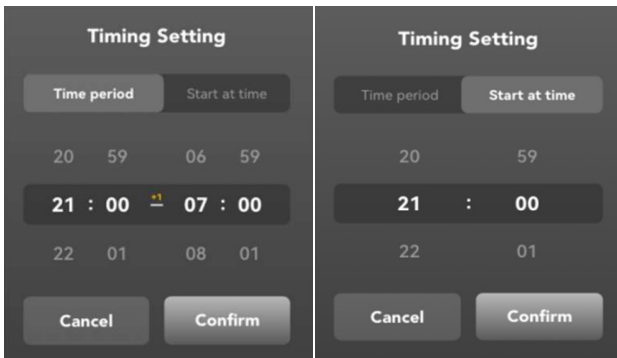
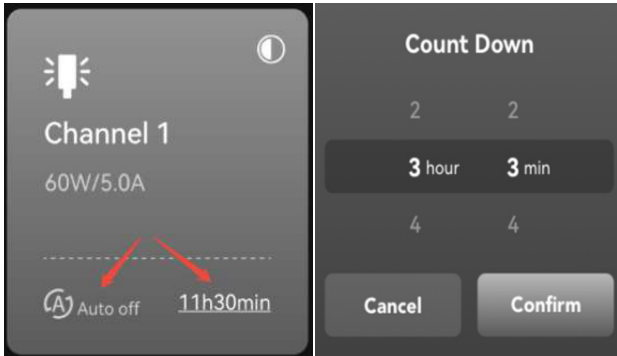

Figure 8: Timed automatic channel on/off function

5.5 Alarm page

- Click "Alarm" to enter the alarm page to view the current alarms. Each alarm will have a corresponding suggestion.
- Click to view the current alarm troubleshooting suggestions.

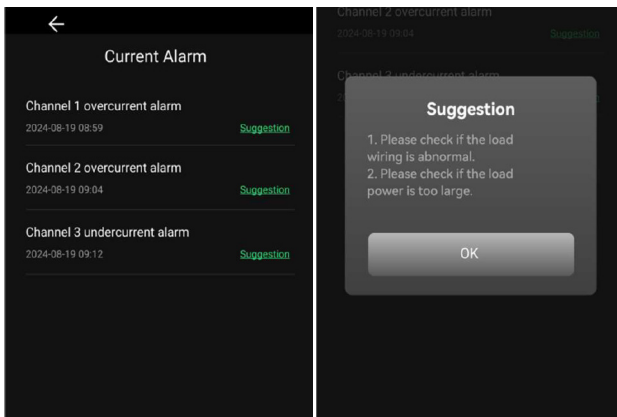

Figure 9: Alarm page

5.6 Settings Page Overview

- Click on "Settings" to enter the settings page for
 - General settings
 - Module Settings
 - Device Settings
 - Bluetooth

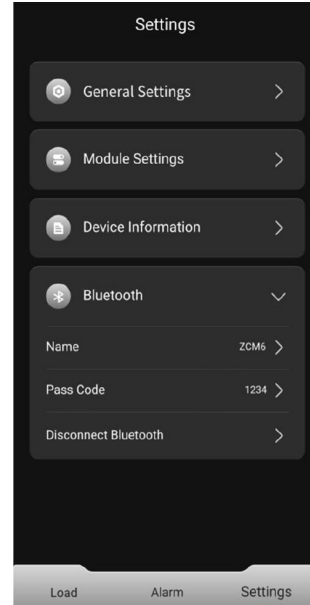



Figure 10: Setting page pverview

5.6.1 General settings

- Click "General settings" to customize the button position.
- Click  to drag the cards to swap the load positions. This order corresponds to the load positions on the homepage.

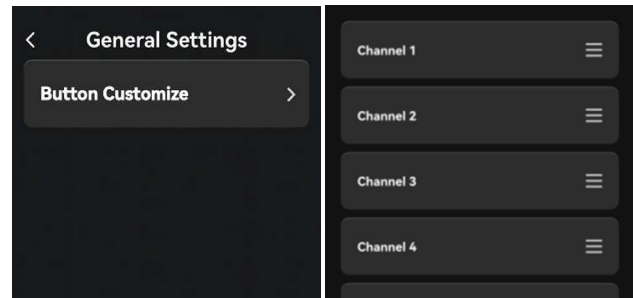

Figure 11: General settings and button position customization

5.6.2 Module Settings

- Click to enter the "Module Settings" page.

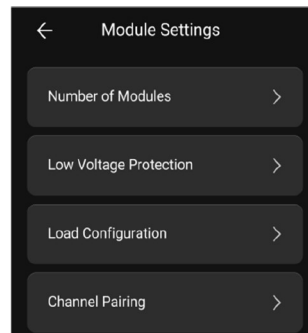

Figure 12: Module Settings

This screen mainly includes the following settings:

- Number of Modules
 - Please configure the number of Zeliox ZCM6 devices through this setting item, the default number of device is "1".
 - When there are multiple Zeliox ZCM6 devices used in parallel, you need to set the total number of Zeliox ZCM6 devices correspondingly.
 - For example, if there are 3 Zeliox ZCM6 devices used in parallel, the quantity should be selected as "3".

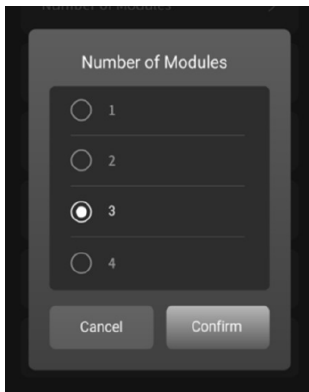

Figure 13: Number of modules

- Low Voltage Protection
 - The user can set the input (battery) low voltage protection value and protection release value, which can be used to prevent the battery from being drained by the Zeliox ZCM6.
 - When the low voltage protection is triggered, the alarm page will display "Low voltage protection" and all load output channels are powered off and disabled.
 - When the input (battery) voltage reaches the protection release value, the low voltage protection is restored, at which time the output channel can be powered on normally.

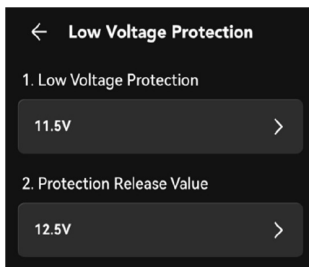

Figure 14: Low voltage protection

Settings item	Options
Low voltage protection	<ul style="list-style-type: none"> • Self-identifying 12V system default: 11.0V Settable range: 10.5-12.5V • Self-identifying 24V system default: 22.0V Settable range: 21.0~25.0V • When the protection value \geq release value the release value needs to be +0.5V from the protection value.

Protection release Value	<ul style="list-style-type: none"> • Self-identifying 12V system default: 11.5V Settable range: 11.0-13.0V • Self-identifying 24V system default: 22.5V Settable range: 22.0~26.0V • When recovery value \leq protection value the protection value needs to be -0.5V above the release value.
--------------------------	--

- Load Configuration
 - Users can configure each load channel separately, click to enter each channel configuration interface, as shown in figure 15:

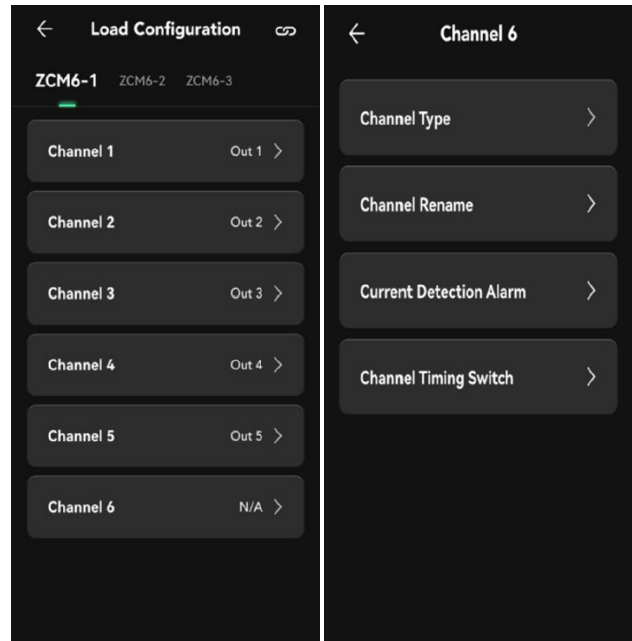

Figure 15: Load configuration

This screen mainly includes the following settings:

Parallel setting of adjacent channels

- Click in the upper right corner of the "Load Configuration" page to enter the page of parallel connection of adjacent channels.
- Adjacent channels can be enabled in parallel two by two (channels 6A,6B are enabled in parallel by default, the remaining channels are not enabled by default).
- When two channels are connected in parallel, the total overload capacity of the channels can be increased to a maximum of 25A, and synchronized switches can be realised for channels connected in parallel.

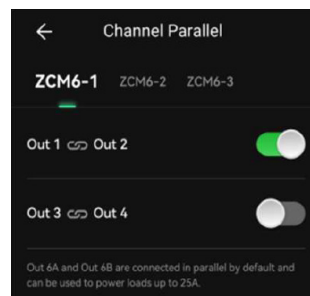

Figure 16: Parallel setting of adjacent channels

Channel Type

The user can customize the load channel type as follows:

- N/A: The homepage load interface does not display the control button for this channel, and the rest of the settings for this channel are not available.
- Constant Powered Load: This channel type of load is turned on by default when the Zeliox ZCM6 is powered on until the Zeliox ZCM6 is powered off. It cannot be controlled via the Load Channel button.
- ON/OFF Controllable load: Controllable load, the channel is switched off by default when Zeliox ZCM6 is first powered on, and the channel can be switched on and off at any time by the load button.
- PWM Modulated Controlled Load: Dimmable Controlled Load, user can do 1%-100% infinitely dimmable, and the dimming gear will be memorized. The channel is switched off by default when Zeliox ZCM6 is first powered on, and the channel can be switched on and off at any time by the load button.

i NOTE

If the load channel type is set to N/A or PWM Modulated Controlled Load, parallel setting of adjacent channels will not be possible.

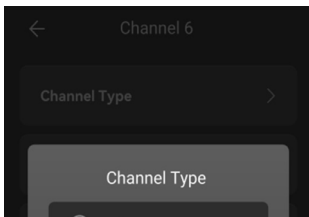

Figure 17: Channel Type

Channel Rename

- The factory default name of the output channel is Channel 1-6, users can rename the output channel and select the channel display icon (16 icons are available in the icon library).
- Channel renaming and icon changes will be displayed in a synchronized update on the Homepage.
- Rename character limit: The name must not be empty and must not contain more than 16 characters.

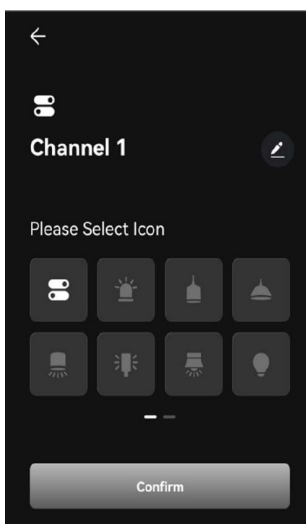

Figure 18: Channel Rename

Current Detection Alarm

- Each output channel of Zeliox ZCM6 is equipped with current sampling, which allows users to customize the output overcurrent protection value or undercurrent alarm value to better understand the load status and protect the loads.

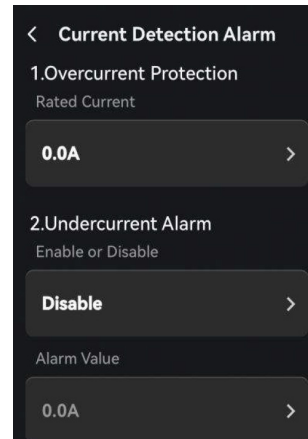

Figure 19: Current Detection Alarm

Settings item	Options	Note
Overcurrent Protection Rated Current	<ul style="list-style-type: none"> Default: 15.0A Settable range: 1.0~15.0A Default if parallel connection of adjacent channels is turned on: 25.0A Programmable range: 1.0~25.0A Channel 6A, 6B default parallel connection Settable range: 1.0~25.0A 	Protection value is 1.2 times the rated value.
Undercurrent Alarm Alarm value	<ul style="list-style-type: none"> Not enabled by default. Settable range: 0.0~10.0A If the adjacent channels are connected in parallel, the range can be set: 0.0~20.0A. Channel 6A, 6B default: parallel connection Settable range: 0.0~20.0A 	

Channel Timing Switch

Users can set the channel to automatically switch on or off at regular intervals according to actual needs, divided into:

- Manual (default): Click to turn on, click to turn off.
- AUTO OFF: The load needs to follow the set countdown logic when it is turned on.
- AUTO ON: The load needs to follow the set start time and end time operation logic when it is turned on/off.

i NOTE

Even in Auto-on or Auto-off mode, manual control is still supported. Manual control has the highest priority.

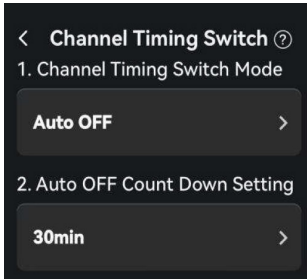

Figure 20: Channel Timing Switch

Settings item	Options	Note
Auto OFF Count Down Setting	<ul style="list-style-type: none"> Default: 30min Settable range: 0h1min-71h59min 	
Auto ON Time Period Setting	<ul style="list-style-type: none"> Default: 9:00-17:00 Settable range: 00:00 - 23:59 (across days) 	Automatic start time can be set and there is no automatic switch off time.

5.6.3 Channel Pairing

- Clicking on the "+" area brings up the Panel pair pop-up, prompting the user to press the same button on the panel twice. If you want to cancel the pairing panel to return to the add page, click the Cancel button.
- After the panel has been paired successfully, go to the channel study page.
- Click on the "Click" button to bring up the Load Selection pop-up window, which includes all loads except constant powered loads.
- Clicking on the "Confirm" button takes you back to the panel information page, where the corresponding load you have just selected is displayed on the button.
- Click on any other PICO button, the corresponding interface button will show green, select the control load to pairing. Once all buttons have been paired, please click "Confirm" to complete the PICO pairing.
- If you want to clear all the loads that have been added to this panel, please click "Clear".
- If you want to completely remove the panel from the Zeliox ZCM6 and clear the data, please click "Remove".

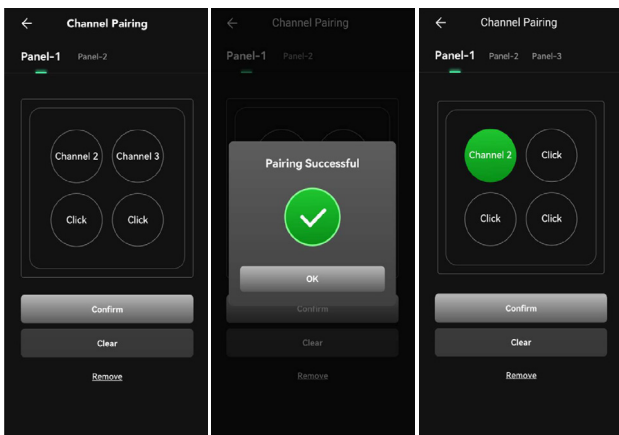

Figure 21: Channel Pairing

5.7 Device Information

- Please click to enter the device information detail page, you can view
 - the device model
 - serial number
 - firmware Code
 - firmware version
 - configuration file version
- Please Click on the yellow character for New Version Upgrade to perform a Bluetooth wireless upgrade of the software and of the configuration.

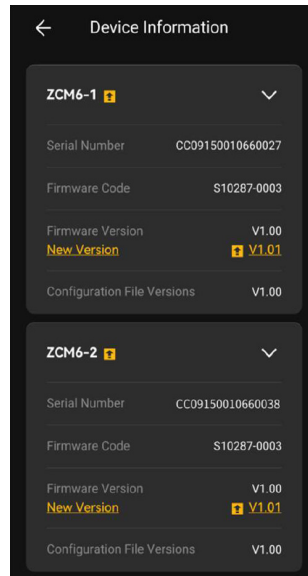

Figure 22: Device information

5.8 Bluetooth

- The Bluetooth option contains
 - Bluetooth Name
 - Pass Code
 - Disconnect Bluetooth

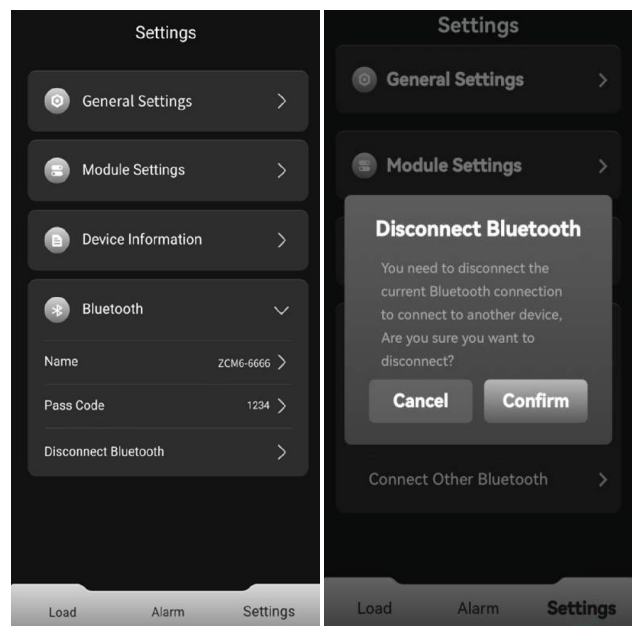

Figure 23: Bluetooth Connection Page

Settings item	Options	Note
Bluetooth Name	<ul style="list-style-type: none"> • Default Zeliox ZCM6 serial number, last four digits • Users can change to any name up to 20 characters. 	
Pass Code	<ul style="list-style-type: none"> • Default: 0000 • The user can change the pass code to another 4 characters. 	If the user forgets the customized 4-digit pass code, please check the last four digits of the Zeliox ZCM6 nameplate serial number, which are the constant pass code.

6 FAQ

No.	Name	Description
1	Input Low voltage protection	<ul style="list-style-type: none"> • Battery Voltage is too low. • Charge the battery.
2	Input Over voltage protection	<ul style="list-style-type: none"> • Battery voltage is too high. • Check the input voltage.
3	Module fault	<ul style="list-style-type: none"> • Restart the Zeliox ZCM6.. • Contact your dealer if the problem still exists.
4	Over temperature protection	<ul style="list-style-type: none"> • Reduce the load.
5	Input overcurrent protection	<ul style="list-style-type: none"> • Reduce the load.
6	OUT 1-6: Undercurrent	<ul style="list-style-type: none"> • Check if the load wiring is abnormal. • Check if the load is faulty.
7	OUT 1-6: Overcurrent protection	<ul style="list-style-type: none"> • Check if the load wiring is abnormal. • Check if the load power is too large.
8	OUT 1-6: Short circuit protection	<ul style="list-style-type: none"> • Check if the load wiring is abnormal. • Check if the load power is too large.
9	OUT 1-6: Fuse failure	<ul style="list-style-type: none"> • Restart the Zeliox ZCM6. • Contact your dealer if the problem still exists.
10	Slave module lost communication	<ul style="list-style-type: none"> • Check if the DIP Switch is set correctly. • Check if the parallel communication cable is connected correctly.

7 Service

7.1 Disassembling the Zeliox ZCM6



RISK OF INJURY!

Disassembling the Zeliox ZCM6 is not permitted.

Therefore, never attempt to

- open or dismantle the module!
- repair, or continue to use a damaged module.
- Dismantling the product will invalidate the module's type

approval and, in the case of motor vehicles, may invalidate the vehicle's operating licence.

7.2 Examination

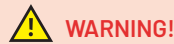

RISK OF INJURY!

The battery contains hazardous liquids and components.

Therefore, never attempt to

- open or dismantle the battery!
- repair, charge or use a damaged battery.
- Never touch the fluid from a broken battery.

- Check the battery for loose and/or damaged cables and contacts, cracks, deformations, leaks or damage of any other kind. If damage to the battery is found, it must be replaced.
- Observe and document the runtime of the new, fully charged battery in a typical consumption cycle up to a capacity limit of 20% as a basis for comparison with the runtimes of older batteries. The runtime of the battery may vary depending on the configuration of the products and the application.
- Check the battery charge status regularly and recharge if necessary. Eberspächer Zeliox lithium iron phosphate batteries continuously self-discharge (approx. 1 - 2 % per month) when not in use or when in storage.
- Carefully monitor batteries whose estimated service life is nearing its end.
- Consider replacing the battery with a new one if any of the following conditions apply:
 - The battery life has fallen below 80% of its original life.
 - The charging time increases significantly.

7.3 Cleaning

If necessary, clean the Zeliox ZCM6 with a soft, dry cloth.



Do not use liquids, solvents or abrasive cleaners to clean the product.

7.4 Transport



CHECK BEFORE TRANSPORT:

- The transport of the used, damaged or recalled product may be restricted or even prohibited in certain cases. Therefore, check all local, national and, if applicable, international regulations applicable to transport.

The packaging of the product can be kept in case the product has to be sent back.

7.5 Technical support

If you have any technical questions or problems with the product, the control unit or the operating software, please contact the following service address:
support-DE@eberspaecher.com

In Austria please contact:
support-AT@eberspaecher.com

In Switzerland please contact:
support-CH-DE@eberspaecher.com

7.6 EU Declaration of Conformity

We herewith declare that the version of the heater placed on the market by us conforms to the applicable provisions of the following EU Directive.

- EU Directive 2011/65/EU
- EU Directive 2014/53/EU



The full Declaration of Conformity can be viewed and downloaded from the download centre at www.eberspaecher-zeliox.com.

7.7 UKCA Declaration of Conformity

We herewith declare that the version of the heater placed on the market by us conforms to the applicable provisions of the following UK Directive.

- Electromagnetic Compatibility Regulation 2016 (EMC)
- Radio Equipment Regulations 2017
- The Restriction of the Use of Certain Hazardous Substances in Electrical and Electronic Equipment Regulations 2012



The full Declaration of Conformity can be viewed and downloaded from the download centre at www.eberspaecher-zeliox.com.

8 Environment

8.1 Certification

The high quality of Eberspächer Zeliox products is the key to our success. To guarantee this quality, we have organised all work processes in the company along the lines of quality management (QM). Even so, we still pursue a large number of activities for continuous improvement of product quality in order to keep pace with the similarly constantly growing requirements made by our customers.

All the steps necessary for quality assurance are stipulated in international standards. This quality is to be considered in a total sense. It affects products, procedures and customer-supplier relationships.

Officially approved public experts assess the system and the corresponding certification company awards a certificate.

Eberspächer Zeliox B.V. has already qualified for the following standards:

Quality management in accordance with ISO TS 9001:2015 and IATF 16949:2016

8.2 Waste disposal and recycling



WEEE Directive 2012/19/EU

Electric and electronic devices as well as batteries must not be disposed of with household waste. Consumers are obliged by law to return electrical and electronic devices as well as batteries at the end of their service lives to the public collecting points set up for this purpose or at the point of sale. Details to this are defined by the national law of the respective country. The symbol on the product, the instruction manual or the package indicates that a product is subject to these regulations.

- Dispose of the battery in accordance with local, state and/or federal laws and regulations, or recycle it.
- The battery must be completely discharged before disposal/recycling.
- Use insulating tape or other covers on the battery terminals to prevent short circuits.
- Batteries can be returned to the manufacturer for proper reuse.
- In many countries, the disposal of electronic devices in standard waste containers is prohibited.

8.2.1 Disassembling the Zeliox ZCM6



WARNING!

RISK OF INJURY!

Disassembling the Zeliox ZCM6 is not permitted.

Therefore, never attempt to

- open or dismantle the module!
- repair, or continue to use a damaged module.
- Dismantling the product will invalidate the module's type approval and, in the case of motor vehicles, may invalidate the vehicle's operating licence.

