



TECHNICAL DOCUMENTATION

# USER MANUAL

## ZELIUX NEO 4000

The User Manual applies to the following Zeliox NEO power system:

**Designation**  
Zeliox NEO 4000

**Order No.**  
62.0150.01.1300

## 1 INTRODUCTION

1.1	Concept of this documentation	3
1.2	Reference documents	3
1.3	Special text structure, presentation and pictograms	3
1.3.1	Lists	3
1.3.2	Cross references	3
1.3.3	Pictograms	3
1.4	Intended use	3
1.4.1	Range of application of the Zeliox NEO	3
1.5	Non-intended use	3
1.6	Disclaimer	3
1.7	Repair	4
1.8	Target groups of this document	4
1.8.1	Instruction obligation of the target groups	4
1.8.2	Accident prevention	4
1.9	Hazard information and safety instructions for operation	4

## 2 PRODUCT INFORMATION

2.1	Safety symbols and markings on the product	5
2.2	Use of the Zeliox NEO	6
2.3	How to operate your Zeliox NEO	6
2.3.1	Front view	6
2.3.2	Side view	7
2.4	Touch Display	7
2.5	How does your Zeliox NEO charge?	7
2.5.1	Drive charge	7
2.5.2	Grid charge	7
2.5.3	Solar charge	7
2.6	What does the Zeliox NEO Insulation Guard do??	8
2.7	What does the Zeliox NEO Heat Pack do??	8
2.8	Prevent overheating!	8
2.9	In case of an alarm	8
2.10	Keep your Zeliox NEO updated with the Zeliox app	9
2.11	Technical data	9

## 3 SERVICE

3.1	Disassembling the Zeliox NEO	10
3.2	Examination	10
3.3	Cleaning	10
3.4	Transport	10
3.5	Technical support	10
3.6	EU Declaration of Conformity	10
3.7	UKCA Declaration of Conformity	10

## 4 ENVIRONMENT

4.1	Certification	11
4.2	Waste disposal and recycling	11

# 1 Introduction

## 1.1 Concept of this documentation

This document supports the end user operating the Zeliox NEO 4000 power system and provides the user with all important information about the power system and its safe operation.



### Please read first!

- The documentation is intended for the operation of the Zeliox NEO 4000 listed on the title page and is valid to the exclusion of any liability claims.
- Before operating the Zeliox NEO 4000, be sure to read this document carefully. It contains important information that is necessary for the operation.
- Be sure to observe all hazard, warning and safety instructions in this document!
- Depending on the version or revision status of the Zeliox NEO 4000, differences may occur compared to this documentation. Please check this before carrying out the installation and take into account possible differences.
- Please keep this document in a safe place for future reference.

## 1.2 Reference documents

### Additional Product Information

Contain additional information for operating the Zeliox NEO 4000.

## 1.3 Special text structure, presentation and pictograms

In this instruction, different facts are highlighted by special notations and pictograms. Refer to the following examples for their meanings and appropriate action.

### 1.3.1 Lists

- This dot (•) indicates a list or action step, introduced by a heading.

### 1.3.2 Cross references

Underlined blue text denotes a cross-reference, which can be clicked in the PDF document. The part of the document named in the text is then displayed.

### 1.3.3 Pictograms



#### DANGER!

“Danger” indicates a situation that can directly result in death or serious injuries if not avoided.

→ This arrow indicates the appropriate measures to avert the imminent danger.



#### WARNING!

“Warning” indicates a situation that can potentially result in death or serious injuries if not avoided.

→ This arrow indicates the appropriate measures to avert the potential danger.



#### CAUTION!

“Caution” indicates a situation that can potentially result in minor or slight injuries or damage to the device.

→ This arrow indicates the appropriate measures to avert the potential danger.



#### NOTE

This note contains recommendations for use and useful tips for the operation, installation and repair of the Zeliox NEO 4000.

## 1.4 Intended use

### 1.4.1 Range of application of the Zeliox NEO 4000

- The Zeliox NEO is an integrated lithium power supply system designed for professional and mobile applications where reliable 230V AC and 12V/24V DC power is required, independent of grid connection.
- The Zeliox NEO is taking care of collecting, storing and distributing power, all packed into one device. Simply plug your tools and appliances into the front power socket or optionally, into other sockets in your vehicle.



#### NOTE

- The Zeliox NEO 4000 must not be installed or operated in vehicles used for the transport of dangerous goods according to ADR.



#### WARNING!

#### SAFETY INSTRUCTIONS FOR THE RANGE OF APPLICATION AND THE INTENDED USE!

The Zeliox NEO 4000 must only be used and operated for the range of application stated by the manufacturer and in compliance with the operation instructions delivered with every product.

## 1.5 Non-intended use

Due to its functional purpose, the Zeliox NEO 4000 is not approved for the following areas of application:

- applications in medicine.
- applications in aviation.



#### WARNING!

Use, operation and deployment of the Zeliox NEO 4000 outside the intended use stated by the manufacturer can cause considerable injuries to people and/or damage to machinery and property.

→ Only use the Zeliox NEO 4000 for the stipulated purpose and in the approved area of use.

## 1.6 Disclaimer

The manufacturer is not liable for damage caused by improper use or incorrect operation. Failure to comply with the safety instructions makes the guarantee null and void and this leads to the exclusion of any liability of Eberspächer Zeliox B.V.

## 1.7 Repair

Repair of the Zeliox NEO 4000 is not permitted. Failure to comply will make the warranty null and void and will result in Eberspächer Zeliox B.V. disclaiming all liability.

## 1.8 Target groups of this document

This document is aimed at the following target groups:

### End user

The “end user” target group includes all natural persons who operate a Zeliox NEO 4000 power system and its components with the help of a control unit or App, regardless of whether they act as a consumer or as part of their job.

### 1.8.1 Instruction obligation of the target groups

Each named target group must fully comply with its instructional obligation. The instruction obligation refers to the forwarding of technical documents.

Technical documents are all documents published by Eberspächer for the installation, operation, use, maintenance of Zeliox power systems and their control units, accessories and spare parts.

#### NOTE

- If not explicitly defined in the following, the technical documents can be passed on printed out as hard copies, on a data carrier or by internet download.
- Current technical documents for Zeliox power systems can be downloaded from the Eberspächer Zeliox website: <https://www.eberspaecher-zeliox.com>

### Responsibility of the installation company

The installation company must pass on the following technical documents to the company that employs them, and it in turn is obliged to pass on the documents to the end user:

- User Manual

### Responsibility of the service company

The service company must pass on the following technical documents to the end user, even if they employ a subcontractor:

- User Manual

#### NOTE

- The named target groups must ensure that the operating instructions produced by the manufacturer for the product are made available to the end user in printed form and in their own national language.
- If necessary this can be a short form of the detailed operating instructions, which are additionally enclosed with the product on a data carrier or are available to download from the internet: <https://www.eberspaecher-zeliox.com>

### 1.8.2 Accident prevention

Observe the general accident prevention regulations and the relevant operating safety instructions.

## 1.9 Hazard information and safety instructions for operation

#### NOTE

- The manufacturer does not assume any responsibility caused by violation of general safety operation requirements or violation of safety standards for design, production and use of equipment.
- The manufacturer is not liable for damage caused by improper installation or maintenance.
- Failure to comply with the installation and maintenance specifications will void the warranty and result in Eberspächer Zeliox B.V. disclaiming all liability.
- All deviations from the safety requirements for operation are to be agreed with the manufacturer in writing before they are implemented.

#### DANGER!

##### RISK OF INJURY, FIRE AND POISONING!

- Do not operate the Zeliox NEO 4000 and its components if they are damaged.
- The Zeliox NEO 4000 must only be operated if it is completely undamaged and only under the conditions specified in this document.
- Do not connect Zeliox NEO 4000 components with reversed polarity.
- Components that are not correctly earthed can lead to dangerous situations.
- Ground the Zeliox NEO before starting the operation.
- Cables that are too small can overheat and cause injury and damage to property.
- Always use cables with sufficient dimensions.

#### CAUTION!

##### GENERAL SAFETY PRECAUTIONS

- It is strictly forbidden to put the product in water or fire to avoid explosion or other dangers.
- Please do not stab, hit, trample or strike the product in any other way.
- Avoid direct sunlight.
- The product needs to be installed in a dry and clean environment.
- During use, when the system needs to be moved or rewired, the power must be completely cut off and the system must be completely shut down, otherwise there will be a risk of electric shock.
- In order to avoid fire and electric shock, please ensure that all cables have good electrical characteristics and suitable wire diameter; it is forbidden to use damaged or too small cables.
- When encountering a fire, please use a dry powder fire extinguisher to extinguish the fire. The use of a liquid fire extinguisher may cause secondary hazards.

**! CAUTION!**

**SAFETY ADVICE FOR THE OPERATION!**

- Keep Zeliox NEO 4000 clean and dry.
- Do not expose Zeliox NEO 4000 to fire, water or solvents.
- Protect Zeliox NEO 4000 from water, dust and contamination.
- Always operate Zeliox NEO 4000 within the maximum permissible technical specifications.
- Observe the plus (+) and minus (-) markings on the Zeliox NEO 4000 and ensure correct electrical connection.
- Install the components of the Zeliox NEO 4000 so that they do not move back and forth under normal operating conditions.
- Operate the Zeliox NEO 4000 in an area of the vehicle that is protected from dirt and water.
- Do not use batteries from different manufacturers, with different capacities, sizes or types together in a Zeliox system.
- The Zeliox NEO 4000 power system may only be installed, maintained or dismantled by a service partner authorised by the manufacturer in accordance with the specifications in this documentation and any special installation recommendations, and must be disposed of, recycled or reconditioned in a professional manner.
- The following measures are not permitted:
- Modifications to components
  - Use of third-party parts not approved by the manufacturer
  - Deviations from legal, safety and/or function-related specifications made in this document with regard to installation and/or operation. This applies in particular to electrical wiring.
- Only use original accessories for operation.
- During electric welding on the vehicle or chassis: To prevent catastrophic damage to the Zeliox NEO 4000 power system, the entire auxiliary power system must be fully isolated from the vehicle chassis. **Follow these procedures precisely:**
  - Turn off the inverter and all power switches in the auxiliary system.
  - Disconnect the vehicle from all external power sources (grid power, solar panels).
  - Disconnect the input cables that connect to the vehicle's starter battery (or the chassis electrical system).
  - Attach the welder's ground clamp directly to the workpiece, as close to the welding point as possible. Never clamp to any component of the electrical system.
  - Failure to comply with these instructions will result in permanent and costly damage to your electronic equipment and create a serious fire hazard.

- Remove and recycle Zeliox NEO 4000 properly when no longer needed.
- Repair to the Zeliox NEO 4000 is not permitted. It will invalidate the type approval of the battery system and, in the case of motor vehicles, may invalidate the vehicle's operating licence.
- The installation space for the components of the Zeliox NEO 4000 is not a storage space and must remain clear. In particular, do not store or transport fuel reserve cans, oil cans, spray cans, gas cartridges and other hazardous materials, fire extinguishers, cleaning rags, clothing, paper, etc. on or next to the components of the Zeliox NEO 4000.

**i NOTE**

- Any deviations from the safety requirements for the operation must be agreed in writing with the manufacturer prior to implementation.

**2 Product information**

**2.1 Safety symbols and markings on the product**

**i NOTE**

The safety symbols and markings are intended to ensure safe operation of the system. They must never be removed or made illegible.



Observe instructions



WEEE Marking: Dispose of the battery in accordance with local, state and federal laws and regulations. Batteries can be returned to the manufacturer. Do not mix with other (industrial) waste.



This product or parts of this product can be recycled.



CE Marking



UKCA Marking

## 2.2 Use of the ZeliOX NEO 4000

The ZeliOX NEO 4000 is taking care of collecting, storing and distributing power, all packed into one device. Simply plug your tools

and appliances into the front power socket or optionally, into other sockets in your vehicle.

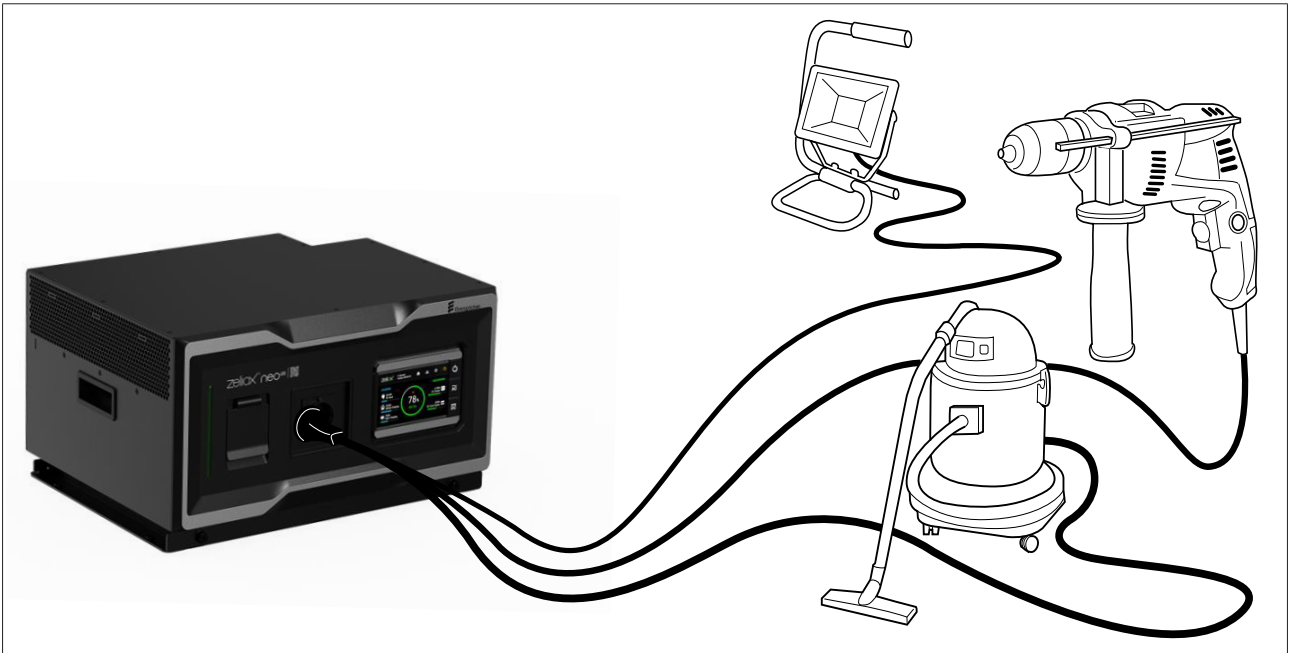

## 2.3 How to operate your ZeliOX NEO 4000

### 2.3.1 Front view

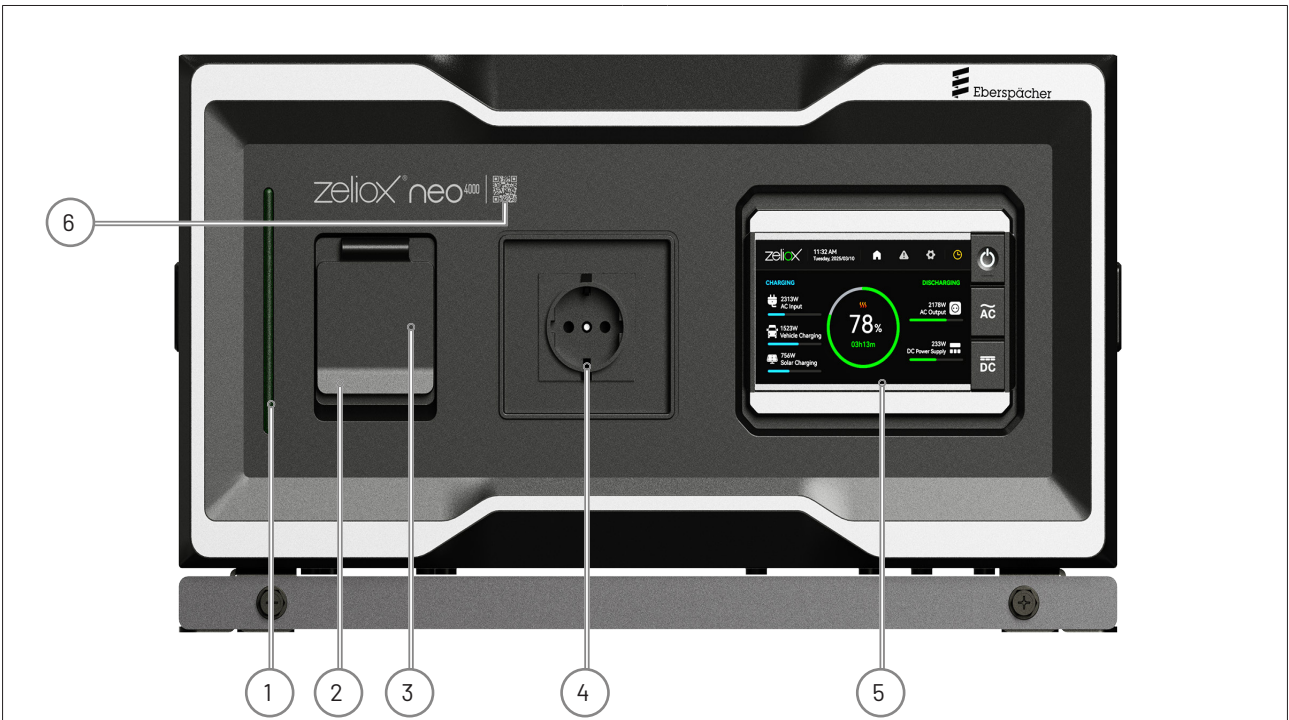

- 1 Status LED
- 2 Individual serial number (behind RCD lid)
- 3 RCD - Electronic Residual Current device
- 4 230 V Output socket
- 5 Touch display
- 6 For further information scan the QR-Code



[www.eberspaecher-zeliOX.com](http://www.eberspaecher-zeliOX.com)

2.3.2 Side view

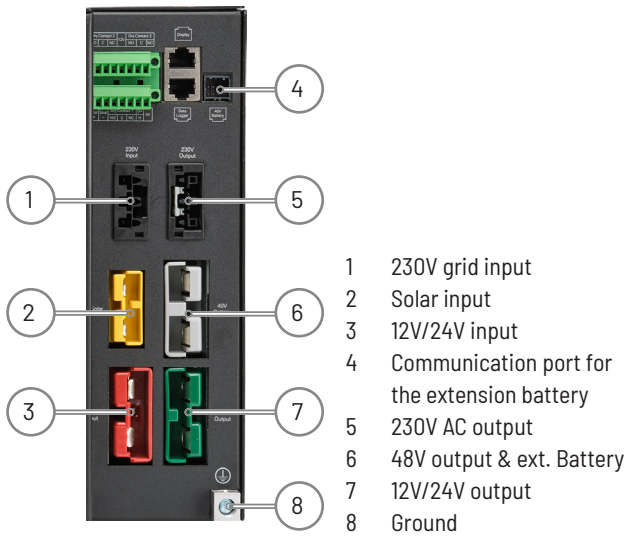

2.4 Touch Display

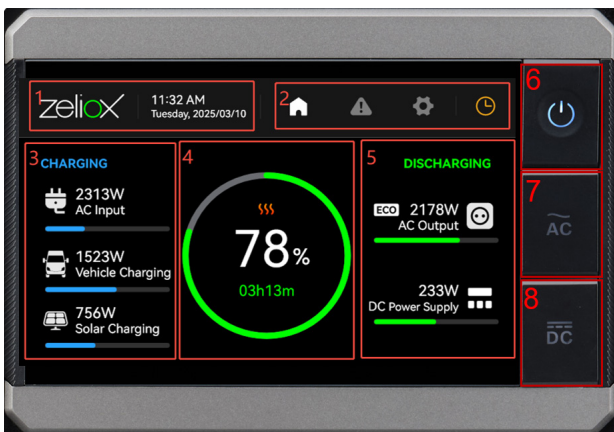

- 1 Zeliox icon, current date / time, Bluetooth connection status
- 2 Left to right: Home, Alert, Settings, Output Control  
Clicking on the icon will lead to the corresponding page.
- 3 CHARGING  
2313W AC Input  
1523W Vehicle Charging  
756W Solar Charging
- 4 Battery SOC and remaining charging/discharging time. Clicking on the icon will give detailed information.
- 5 DISCHARGING  
ECO 2178W AC Output  
233W DC Power Supply
- 6 Power button. Long-press the power button (> 2 seconds) to turn on/off the machine.
- 7 AC output ON / OFF
- 8 DC output ON / OFF

2.5 How does your Zeliox NEO 4000 charge?

- The charging process runs automatically.
- The charging options are shown below.

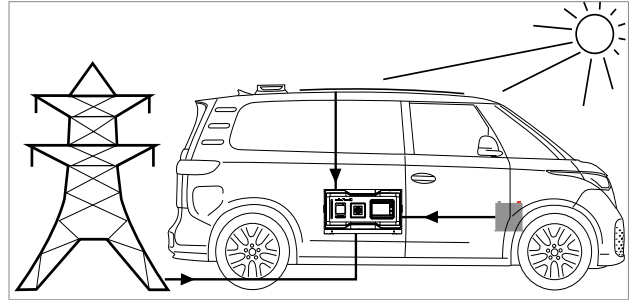

2.5.1 Drive charge

**i** NOTE

- Electric vehicles have a limited charging speed for accessories and is depending on vehicle make and type.
- When the system is ON and being charged by the alternator, the 12V/24V Output and AC Output can be activated or deactivated by ON/OFF buttons.
- If the Zeliox NEO 4000 is off when the vehicle is charging the system, the 12V/24V DC output and 230V AC output can not be activated.

2.5.2 Grid charge

**i** NOTE

- When connected to the grid, the 230V inverter is switched off and a direct bypass is active.
- The RCD switch will protect against electrical faults.
- When the system is ON and being charged by the grid, the 12V/24V Output can be activated or deactivated by DC ON/OFF button. There will be AC by-pass output all the time.
- If the Zeliox NEO 4000 is off, the DC output is not activated but there will be AC by-pass output.

2.5.3 Solar charge

**i** NOTE

- To harvest sun energy, optional solar panels need to be installed.
- Charging speeds may vary, depending on the intensity of the sunlight.
- When the system is ON and being charged by solar, the 12V/24V Output and AC Output can be activated or deactivated by ON/OFF buttons.
- If the Zeliox NEO 4000 is off, the 12V/24V DC output and 230V AC output can not be activated.

### 2.6 What does the ZeliOX NEO 4000 Insulation Guard do??

ZeliOX NEO 4000 is standard equipped with an insulation guard. When working in a mobile environment you are not earth grounded and thus not protected in case of a short circuit due to moisture or cable damage. The ZeliOX insulation guard protects you against this risk.

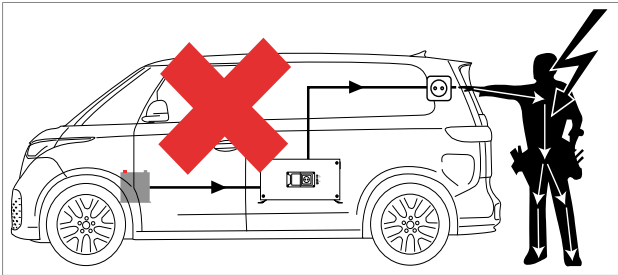

#### Risk

- In a vehicle you are not earth grounded!
- In the event of a short circuit a RCD (Residual Current Device) will not be activated.
- Person in contact will get an electrical shock or could get electrocuted.

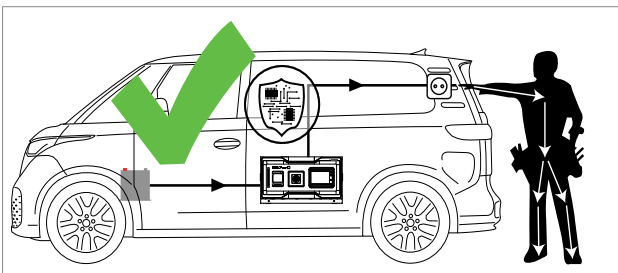

#### Working of the ZeliOX NEO 4000 insulation guard

- It detects short circuits due to moisture or touching bare wires.
- It automatically shuts down the ZeliOX NEO 4000.
- In accordance with DIN VDE 0701/0702 and NEN 1010.

### 2.7 What does the ZeliOX NEO 4000 Heat Pack do??

- The built-in Li-ion battery in the ZeliOX NEO 4000 has a special built-in heating pack. Operating Li-ion batteries in low temperatures, could shorten the battery life significantly.
- Below 5° Celsius the heat pack will automatically switch-on when external power sources (grid, solar, alternator) are presented.
- The charging process will start, after it has heated the battery cells sufficiently.

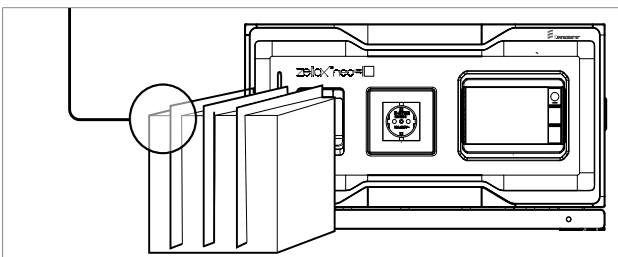

#### **i** NOTE

In frequent low temperature environments, we recommend connecting the ZeliOX to the grid as much as possible and switch it off if not in use.

### 2.8 Prevent overheating!

- Make sure that the side ventilation openings are clear.  
Recommendation: 4 cm air clearance to rack or vehicle walls.
- Should the ZeliOX NEO 4000 become overheated, switch-off the device and let it cool down.



- 1 Make sure the air inlet and outlet are not obstructed.

### 2.9 In case of an alarm

- First look into the ZeliOX App to see what happened.
  - Icon yellow warning triangle: Clicking will show the most recent alarm message.
  - Icon Gear: Click and select "Events" for the full message history.

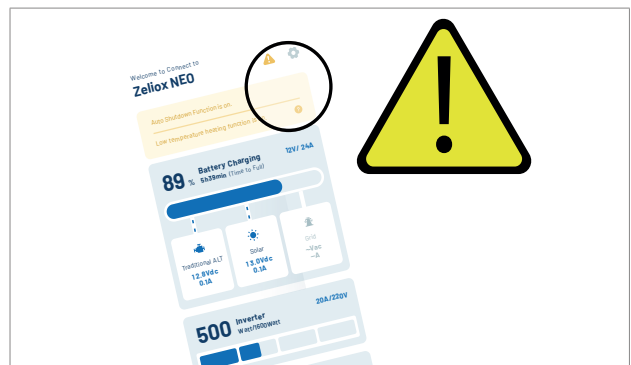

- Still don't know what to do? Contact your installer or dealer.

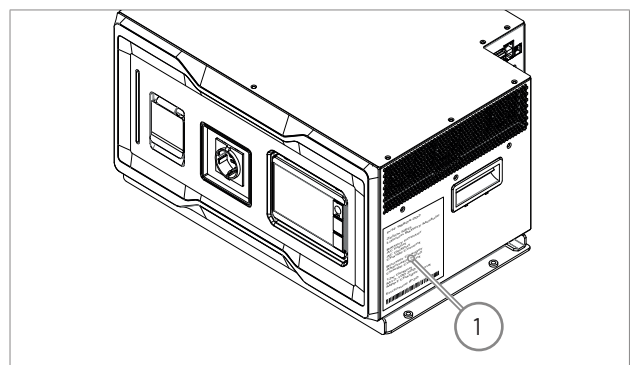

- 1 Serial Number on right side of the ZeliOX NEO 4000.

#### **i** NOTE

When contacting your installer be sure you have the s/n serial number of the ZeliOX NEO 4000 at hand.

### 2.10 Keep your Zeliox NEO 4000 updated with the Zeliox app

The app gives you real-time information on battery status, remaining battery time, charging details, current consumption, (dis-)charging history, battery lifetime and alarm events. You also can use the app to keep your Zeliox NEO 4000 up to date with new developed features and the latest firmware.

> Please scan the appropriate QR Code shown below to start the download process.



Google Play Store



iOS App Store

> Information on the latest updates, improvements and fixed problems can be found in the App Store as well.

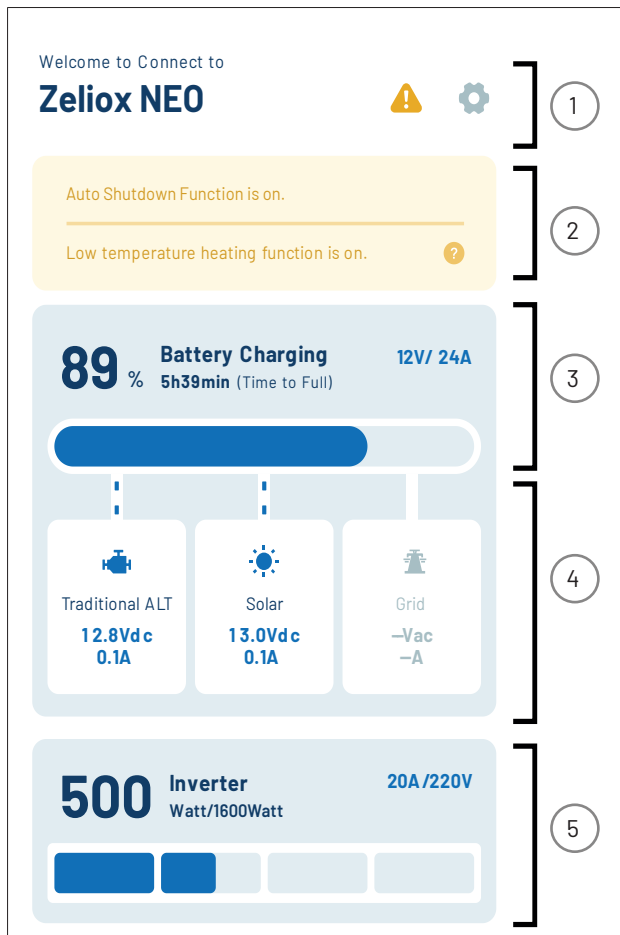

- 1 Menu / Alarms
- 2 Events / Functions
- 3 Current battery status
- 4 Current charging status
- 5 Current consumption

### 2.11 Technical data

Model	Zeliox NEO 4000	
Battery type		LiFePO4
Battery capacity	V dc	48 (50 Ah, 2400Wh)
Maximum discharging current	A dc	100
Continuous charging current	A dc	50
Battery cell heating (support reservation heating)	°C	min. 0.6
<b>Booster charger</b>		
ALT input voltage range	V dc	12/24
ALT input current	A dc	120
Efficiency	%	95.5 @ 12V 97.5 @ 24V
<b>MPPT charger</b>		
PV input voltage range	V dc	15 ... 60 @25 °C
Max. PV short circuit current	A dc	50
Max. power of PV panels	W	1800
Max. charging current	A dc	30
MPPT efficiency	%	> 99.5
<b>Battery inverter</b>		
• AC input		
Voltage range	V ac	175 ... 265
Frequency range	Hz	45 ... 65
Current (transfer switch)	A	Def. 16, Max. 25
• AC output		
Voltage	A ac	230 ±3%
Frequency	Hz	50 ±1%
Harmonic distortion	%	≤ 2%
Max. output power	V A	4000 (cont.), 8000 (2 s)
RCCB	A / mA	32 / 30
• Charger		
Charge voltage	V	53.2
Cont. AC charge current	A dc	50
Transfer time	ms	2
• Inverter / AC charger efficiency	%	Maximum 96.5 Full load 94.8
<b>DC output</b>		
Output voltage range	V dc	12/24
Continuous current	A dc	100
<b>External battery port</b>		
Output voltage range	V dc	43.5 ... 53.2
Battery model	V dc	48 (50 Ah, 2400 Wh)
Continuous current	A dc	100
Default isolation guard	kΩ	100
Sleep mode consumption	mA	< 0.1
Self-discharge rate / month	%	< 3
Storage temperature (< 70% rH)	°C	-25 ... +45 (< 1 month) 0 ... +35 (< 1 year)
Operating temperature	°C	-20 ... +55
IP rating	IP	20
Product Dimensions (LxWxH)	mm	494.4 x 380.5 x 270
Product weight	kg	43
Package Dimensions (LxWxH)	mm	575 x 485 x 365
Package weight	kg	47
Certifications		CE, UKCA, E-mark

**CAUTION!**

Failure to comply with the ambient conditions stated in the technical data can result in malfunctions.

**NOTE**

Provided no other values are given, the technical data provided is with the usual tolerances of  $\pm 10\%$  at rated voltage, 20 °C ambient temperature and reference altitude Esslingen.

### 3 Service

#### 3.1 Disassembling the Zeliox NEO 4000

- The Zeliox NEO 4000 contains a 40V 50Ah LiFePO<sub>4</sub> battery.
- Always obey to the following safety warnings:

**WARNING!**
**RISK OF INJURY!**

**Disassembling the Zeliox NEO 4000 is not permitted.**

Therefore, never attempt to

- open or dismantle the battery.
- repair, or continue to use a damaged battery.
- Dismantling the product will invalidate the module's type approval and, in the case of motor vehicles, may invalidate the vehicle's operating licence.

#### 3.2 Examination

**WARNING!**
**RISK OF INJURY!**

**The battery contains hazardous liquids and components.**

Therefore, never attempt to

- open or dismantle the battery.
  - repair, charge or use a damaged battery.
  - Never touch the fluid from a broken battery.
- Check the battery for loose and/or damaged cables and contacts, cracks, deformations, leaks or damage of any other kind. If damage to the battery is found, it must be replaced.
  - Observe and document the runtime of the new, fully charged battery in a typical consumption cycle up to a capacity limit of 20% as a basis for comparison with the runtimes of older batteries. The runtime of the battery may vary depending on the configuration of the products and the application.
  - Check the battery charge status regularly and recharge if necessary. Zeliox LiFePO batteries continuously self-discharge (approx. 1 - 2 % per month) when not in use or when in storage.
  - Carefully monitor batteries whose estimated service life is nearing its end.
  - Consider replacing the battery with a new one if any of the following conditions apply:
    - The battery life has fallen below 80% of its original life.
    - The charging time increases significantly.

#### 3.3 Cleaning

If necessary, clean the Zeliox NEO 4000 with a soft, dry cloth.

**NOTE**

Do not use liquids, solvents or abrasive cleaners to clean the product.

#### 3.4 Transport

**NOTE**
**CHECK BEFORE TRANSPORT:**

- The transport of the used, damaged or recalled product may be restricted or even prohibited in certain cases. Therefore, check all local, national and, if applicable, international regulations applicable to transport.

The packaging of the product can be kept in case the product has to be sent back.

#### 3.5 Technical support

If you have any technical questions or problems with the product, the control unit or the operating software, please contact the following service address:

support-DE@eberspaecher.com

In Austria please contact:

support-AT@eberspaecher.com

In Switzerland please contact:

support-CH-DE@eberspaecher.com

#### 3.6 EU Declaration of Conformity

We herewith declare that the version of the Zeliox NEO 4000 power system placed on the market by us conforms to the applicable provisions of the following EU Directive.

EU Directive 2014/53/EU

EU Directive 2011/65/EU



The full Declaration of Conformity can be viewed and downloaded from the download centre at [www.eberspaecher-zeliox.com](http://www.eberspaecher-zeliox.com).

#### 3.7 UKCA Declaration of Conformity

We herewith declare that the version of the Zeliox NEO 4000 power system placed on the market by us conforms to the applicable provisions of the following UK Directive.

Radio Equipment Regulations, Statutory Instrument 2017 No. 1206



The full Declaration of Conformity can be viewed and downloaded from the download centre at [www.eberspaecher-zeliox.com](http://www.eberspaecher-zeliox.com).

## 4 Environment

### 4.1 Certification

The high quality of Eberspächer products is the key to our success. To guarantee this quality, we have organised all work processes in the company along the lines of quality management (QM). Even so, we still pursue a large number of activities for continuous improvement of product quality in order to keep pace with the similarly constantly growing requirements made by our customers.

All the steps necessary for quality assurance are stipulated in international standards. This quality is to be considered in a total sense. It affects products, procedures and customer-supplier relationships.

Officially approved public experts assess the system and the corresponding certification company awards a certificate.

Eberspächer Climate Control Systems International GmbH has already qualified for the following standards:

#### **Quality management in accordance with**

**ISO TS 9001:2015 and IATF 16949:2016**

#### **Environmental management system in accordance with**

**ISO 14001:2015**

### 4.2 Waste disposal and recycling



#### **WEEE Directive 2012/19/EU**

Electric and electronic devices as well as batteries must not be disposed of with household waste. Consumers are obliged by law to return electrical and electronic devices as well as batteries at the end of their service lives to the public collecting points set up for this purpose or at the point of sale. Details to this are defined by the national law of the respective country. The symbol on the product, the instruction manual or the package indicates that a product is subject to these regulations.

- Dispose of the battery in accordance with local, state and/or federal laws and regulations, or recycle it.
- The battery must be completely discharged before disposal/recycling.
- Use insulating tape or other covers on the battery terminals to prevent short circuits.
- Batteries can be returned to the manufacturer for proper reuse.
- In many countries, the disposal of electronic devices in standard waste containers is prohibited.

