



5 YEARS WARRANTY*

Register your ZeliOX here for up to 5 years warranty

*5 years consist of statutory warranty plus additional warranty extension. Registration within 3 months required. Statutory warranty varies by country.

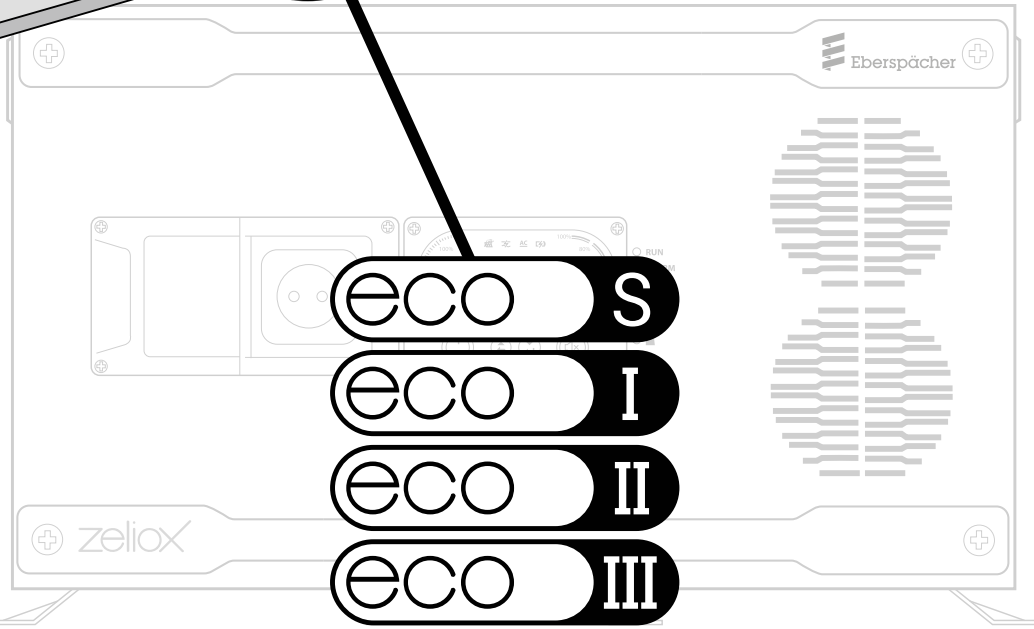
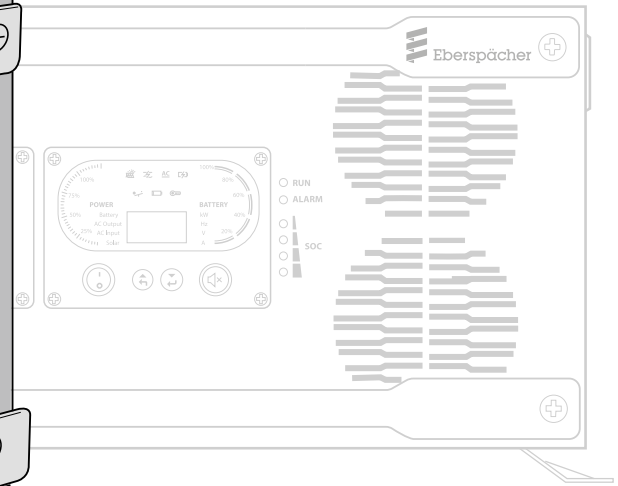
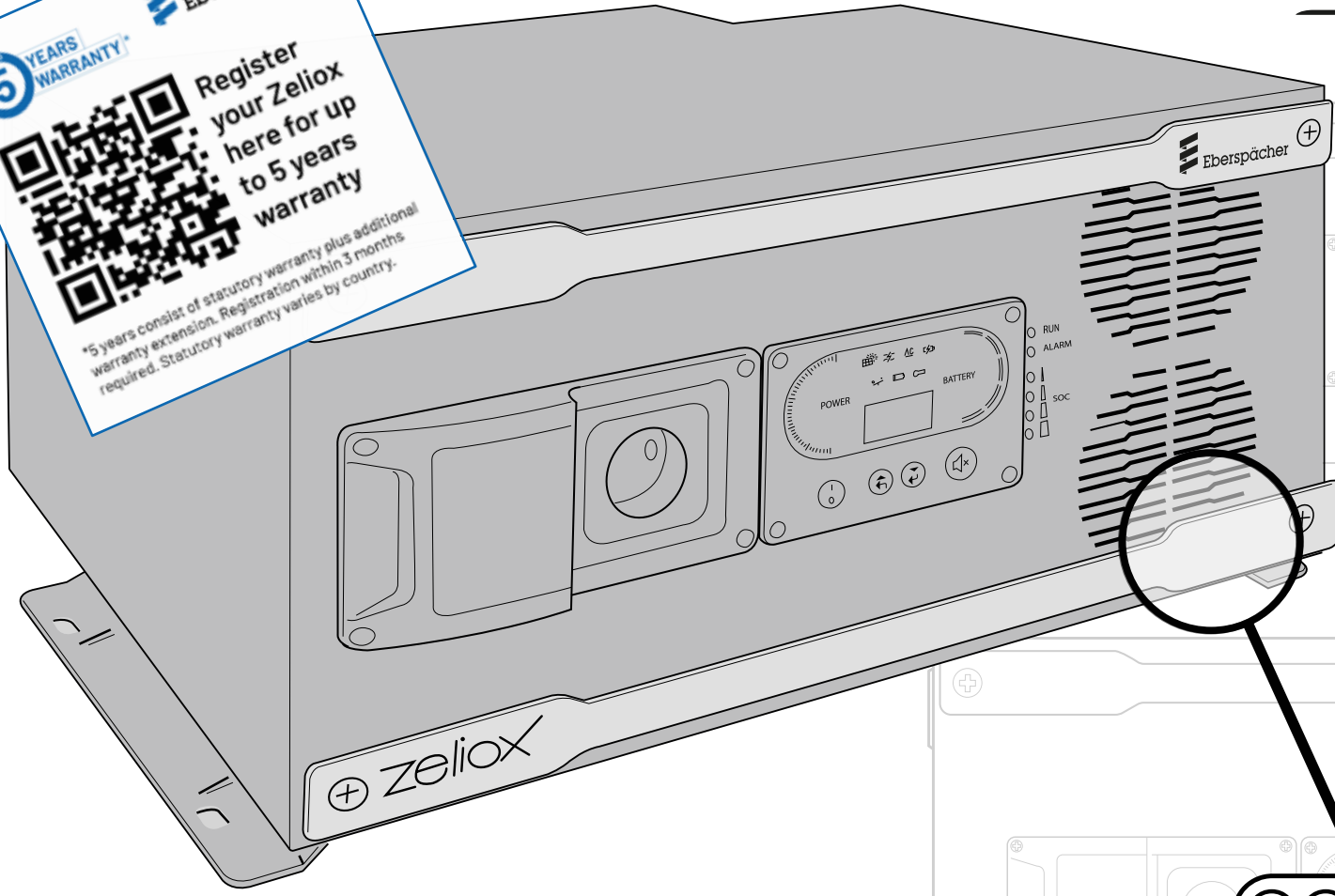
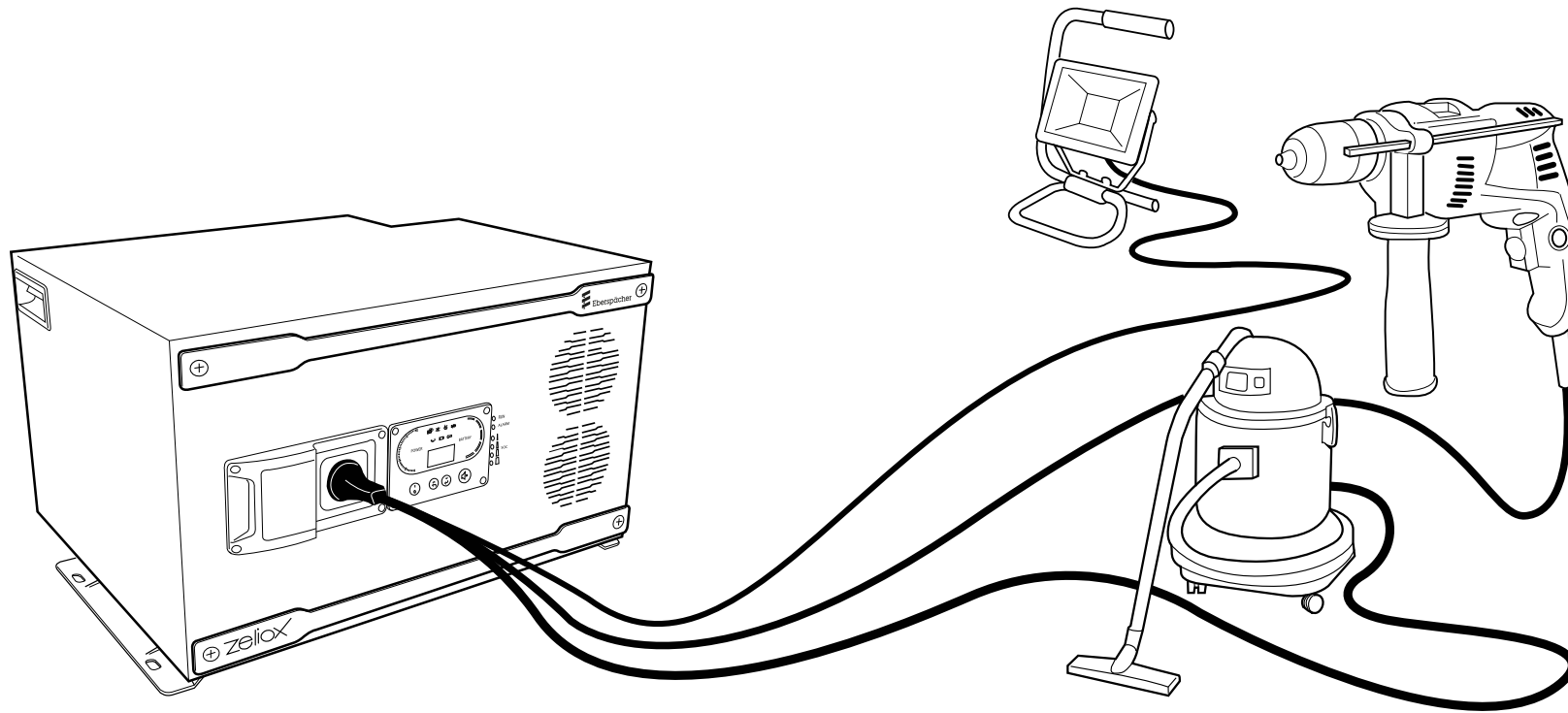

Table of contents

1. Use of the ECO	3
2. Keep you Zeliox ECO updated with the ECO-App	4
3. How to operate your Zeliox ECO?	5
4. Explanation of the display	6
5. How does your Zeliox ECO charge?	8
6. Zeliox ECO capacity and charging time	9
7. What does the Zeliox ECO Insulation Guard do?	10
8. What does the Zeliox Heat Pack do?	11
9. Prevent overheating!	12
10. In case of an alarm	13
11. Compatible products	14
12. Zeliox ECO specifications	17
13. Zeliox App - User functions & settings	19
14. Disposal or recycle	24

1. Use of the ECO

The Zeliox ECO is taking care of **collecting, storing** and **distributing** power, all packed into one device. **Simply** plug your tools and appliances into the front power socket or optionally, into other sockets in your vehicle. The **maximum available capacity** is depending on the ECO type (see chapter 6 for more details).



2. Keep your Zeliox ECO updated with the ECO-App

The app gives you **real-time information** on battery status, remaining battery time, charging details, current consumption, (dis-)charging history, battery lifetime and alarm events. You also can use the app to keep your ECO **up to date** with **new developed features** and the latest **firmware**.

Make sure that your **Bluetooth** is switched on.



Zeliox

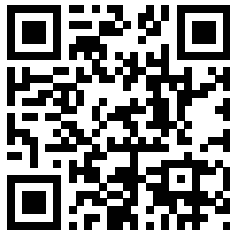

Service portal

You can find us in Google Play store app or Apple store.

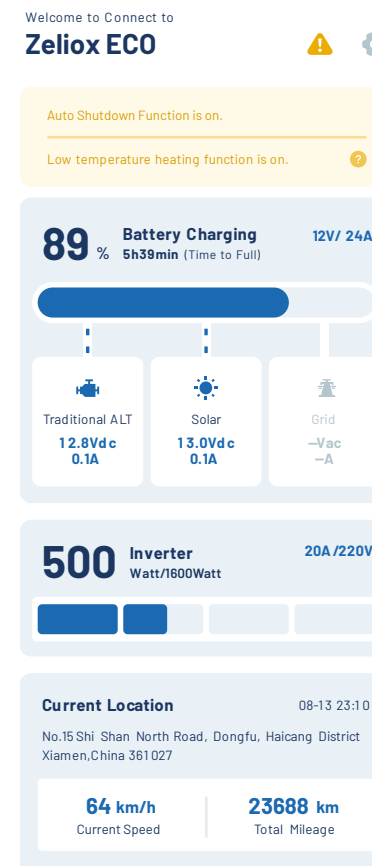

Menu / Alarms

Events / Functions

Current battery status

Current charging status

Current consumption

3. How to operate your Zeliox ECO?

Switch RCD ON (upwards) ①		
Front ON/OFF 	Remote Switch (optional) 	Grid Charging (only ECO I, II, III)
Switch ON ②	Push ON ③	Auto ON ④ Should your home grid not support 16A, then switch the Zeliox ON by hand.
Use front power socket ⑤		
Or use optional power sockets in the vehicle ⑥		
Switch OFF (if not in use)	Push OFF (if not in use)	Auto OFF
Warning: use the same switch (front or remote) to switch ON or OFF. Do not mix both switches.		

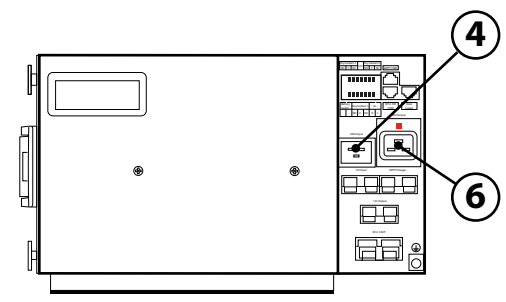
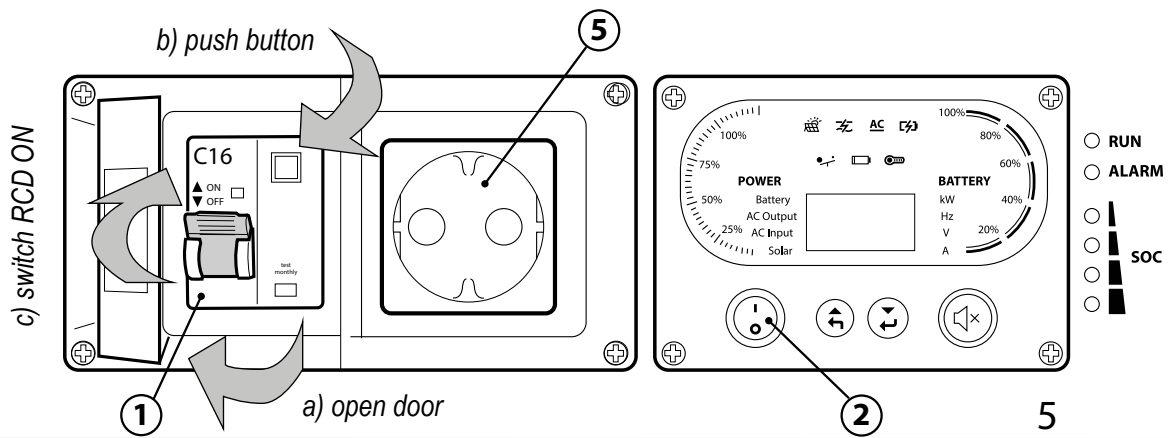
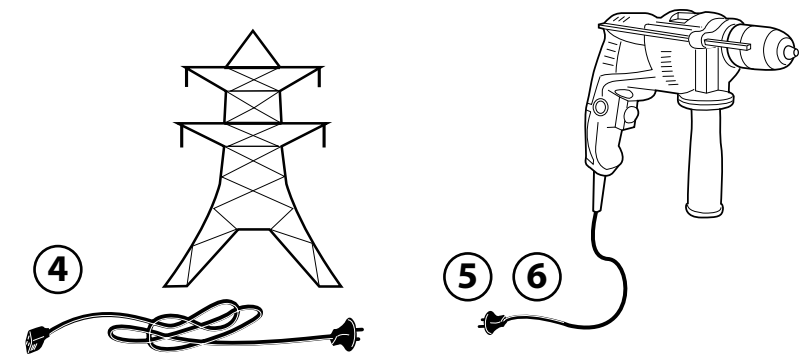
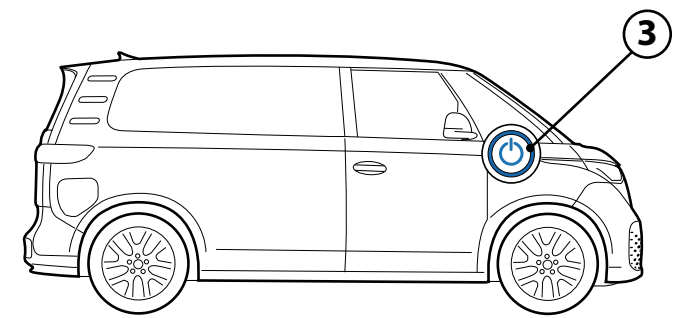

4. Explanation of the display

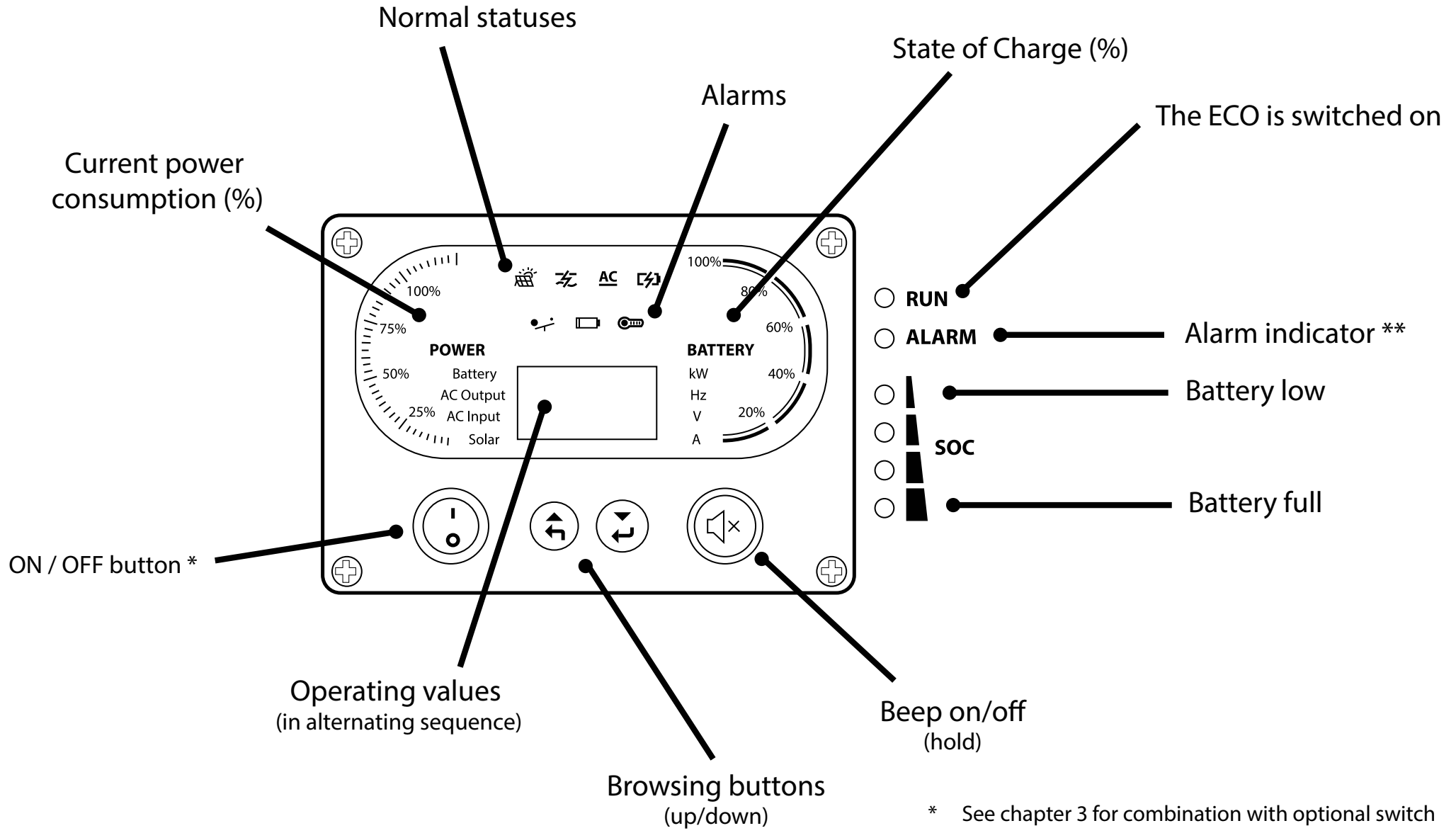

* See chapter 3 for combination with optional switch
 ** Consult user manual for detailed information

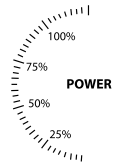

According to the current power, display as below:
 0-25% display at 25%
 25%-50% display at 50%
 50%-75% display at 75%
 75%-100% display at 100%
 Overload display at full range

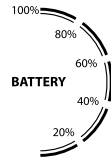

① According to the current SOC value, display as below:
 When SOC 0%, no display;
 SOC 0-20% display at 20%;
 SOC 20%-40% display at 40%;
 SOC 40%-60% display at 60%;
 SOC 60%-80% display at 80%;
 SOC 80%-100% display at 100%.
 ② When charging, the SOC light where it is located flashes, and it does not flash at 100%;
 ③ No flashes during discharging.

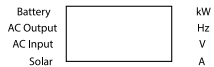

Display showing the various values, namely Battery, AC output, AC input and Solar with the corresponding unit (kW, Hz, V and A).



On/Off button, arrows for values, silent operating button.

- RUN
- ALARM
- SOC

When the Zeliox ECO has an alarm, MEZ displays ALM; and when ECO has fault, it displays Err.

State Of Charge;
 1 LED = 0-25%, 2 LEDs = 25-50%, 3 LEDs = 50-75%, 4 LEDs = 75-100%



Solar on, the icon always on;
 Solar off, the icon is off



Inverter on, the icon always on;
 Inverter off, the icon is off



With AC input, the icon always on;
 Without AC input, the icon is off



Always on when charging;
 Off when discharging or standby



Flashes when the inverter is in overload alarm;
 always on when the inverter is in overload protection



Flashes when the battery is in under-voltage alarm;
 Always on when the battery is in under-voltage protection.



Flashes when the BMS board is in over-temperature alarm;
 Always on when the SP/booster charger/inverter/BMS is/are in over-temperature protection

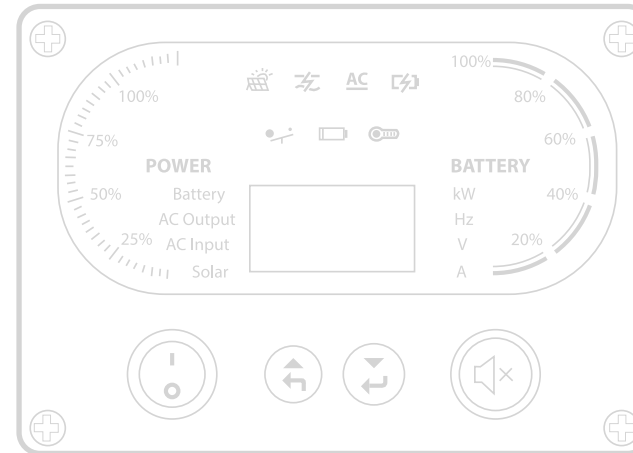

- RUN
- ALARM
- SOC



5. How does your Zeliox ECO charge?

This will run automatically and the charging options are shown below.
The ECO App (see chapter 2) gives you detailed information on the charging.

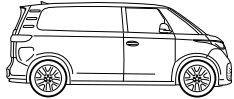

Drive charge

Remark: Electric vehicles have a limited charging speed for accessories and is depending on vehicle make and type. PLEASE NOTE: During charging, the 12V output is activated and any connected loads will be powered.



Grid charge *(only ECO I, II, III)*

Remark: When connected to the grid, the 230V inverter is switched off and a direct bypass is active. The RCD switch will protection against electrical faults. PLEASE NOTE: During charging, the 12V and 230V outputs are activated and any connected loads will be powered.

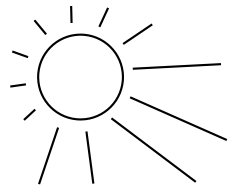

Solar charge *(option)*

Remark: To harvest sun energy, optional solar panels and a MPPT-converter needs to be installed. Ask your installer for Zeliox approved products, for the highest efficiency. Charging speeds may vary, depending on the intensity of the sunlight. PLEASE NOTE: During charging, the 12V output is activated and any connected loads will be powered.

Important: If your Zeliox ECO is switched off, the **charging** process of the battery will run in the background. Charging will activate the **display** and power the **12V output**. Additionally if you charge from the grid, the **230V outputs** are activated. Keep in mind that any **loads** connected to these outputs, will be **powered** during the charging process!

The display will deactivate automatically when the charging process is finalized.

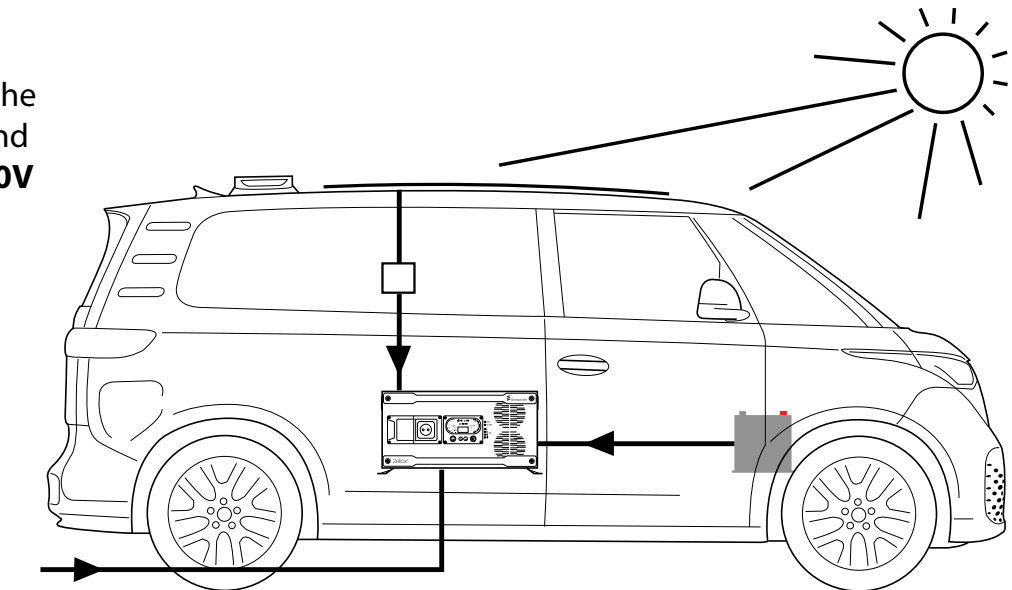
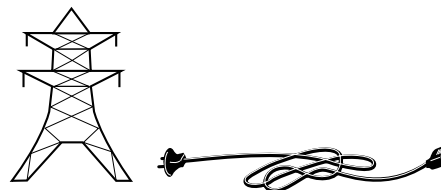

6. Zeliox ECO capacity and charging times*

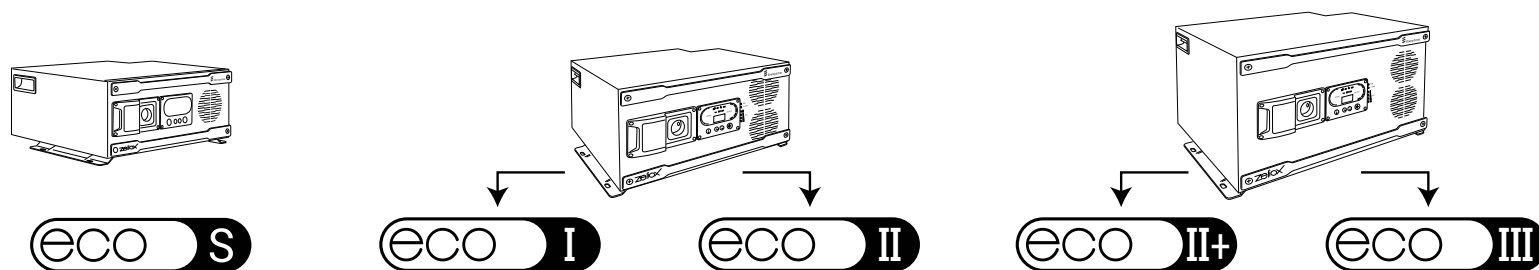

		1000 Watt	1600 Watt	2000 Watt	2000 Watt	3000 Watt
Grid 230V						
Battery capacity		600Wh / 50Ah	1300Wh / 100Ah	1300Wh / 100Ah	2600Wh / 200Ah	2600Wh / 200Ah
Ride	<i>Charging power</i>	426W	426W	426W	852W	852W
	<i>Charging time</i>	1h30m	3h	3h	3h	3h
Land line	<i>Charging power</i>	N/A	852W	852W	1420W	1704W
	<i>Charging time</i>	N/A	1h30m	1h30m	1h45m	1h30m
Solar cell**	<i>Charging power</i>	200Wp	200Wp	200Wp	400Wp	400Wp
	<i>Charging time</i>	3h15m	6h25m	6h25m	6h24m	6h24m

* Without external batteries

** Please note the comments in section 5

7. What does the Zeliox ECO Insulation Guard do?

The Zeliox ECO is standard equipped with an insulation guard. When working in a mobile environment you are not earth grounded and thus not protected in case of short circuit due to moisture or cable damage. The Zeliox ECO insulation guard protects you against this risk.

Risk

- In a vehicle you are not earth grounded!
- In the event of a short circuit a RCD (circuit breaker) will not be activated
- The person will get an electrical shock or could get electrocuted

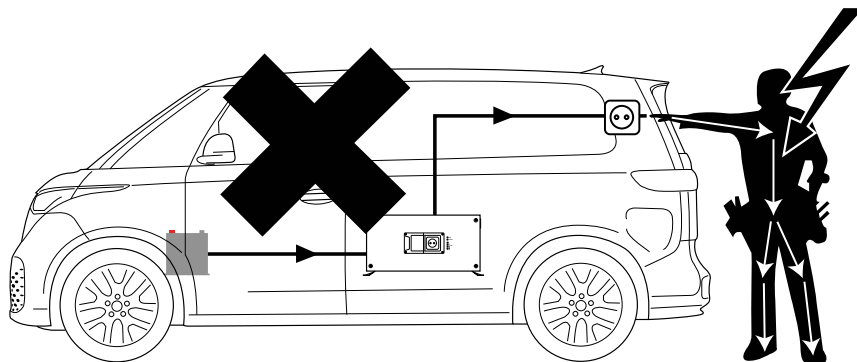

Standard

Working of an insulation guard

- It detects short circuits due to moisture or touching bare wires
- It automatically shuts down the Zeliox ECO
- In accordance with DIN VDE 0701/0702 and NEN 1010

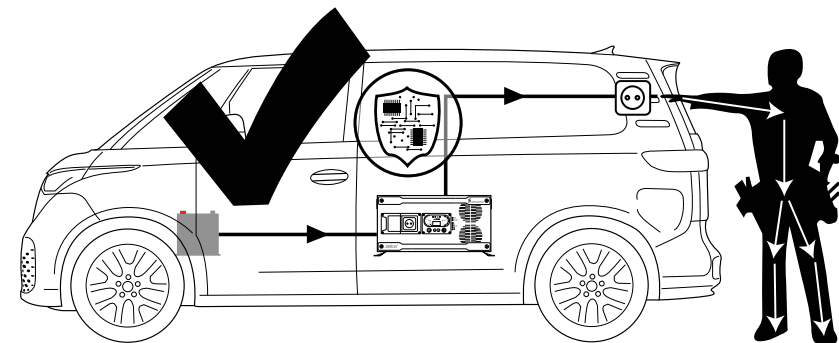

Zeliox ECO

8. What does the Zeliox ECO Heat Pack do?

The built-in Li-ion battery in the Zeliox ECO has a special built-in heating pack. Operating Li-ion batteries in low temperatures, could shorten the battery life significantly.

Below 5° Celsius, our heat pack will automatically switch on. The charging process will start, after it has heated up the battery cells sufficiently.

In frequent low temperature environments, we recommend connecting the Zeliox to the grid as much as possible and switch it off if not in use.

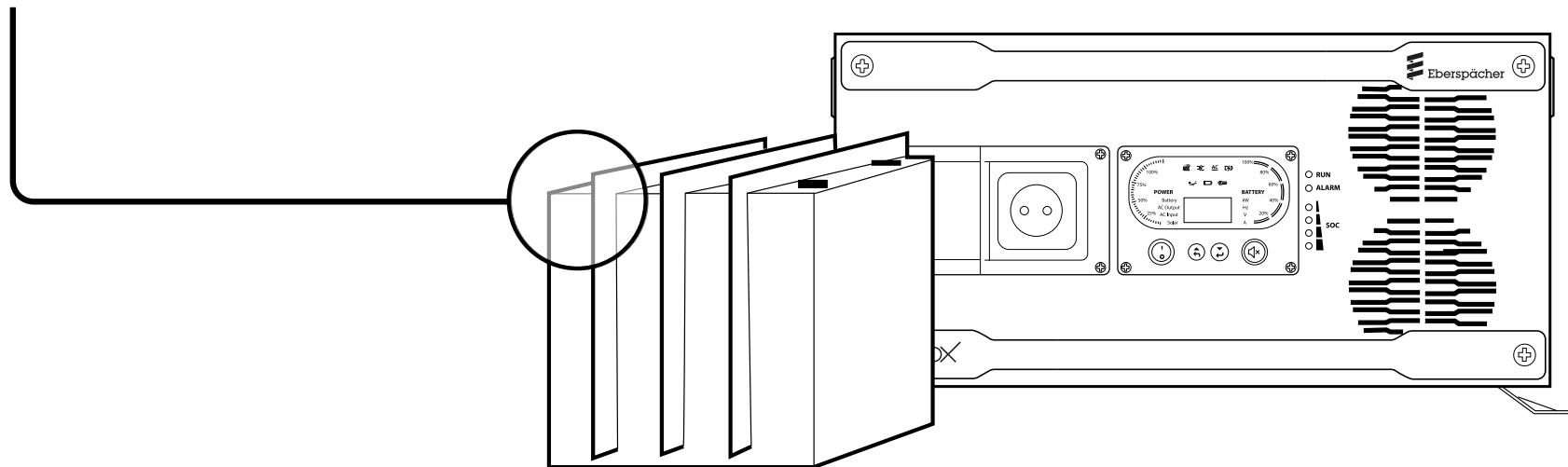

9. Prevent overheating!

Make sure that the front and rear ventilation openings are clear. Should the Zeliox ECO become overheated, switch the device off and let it cool down.

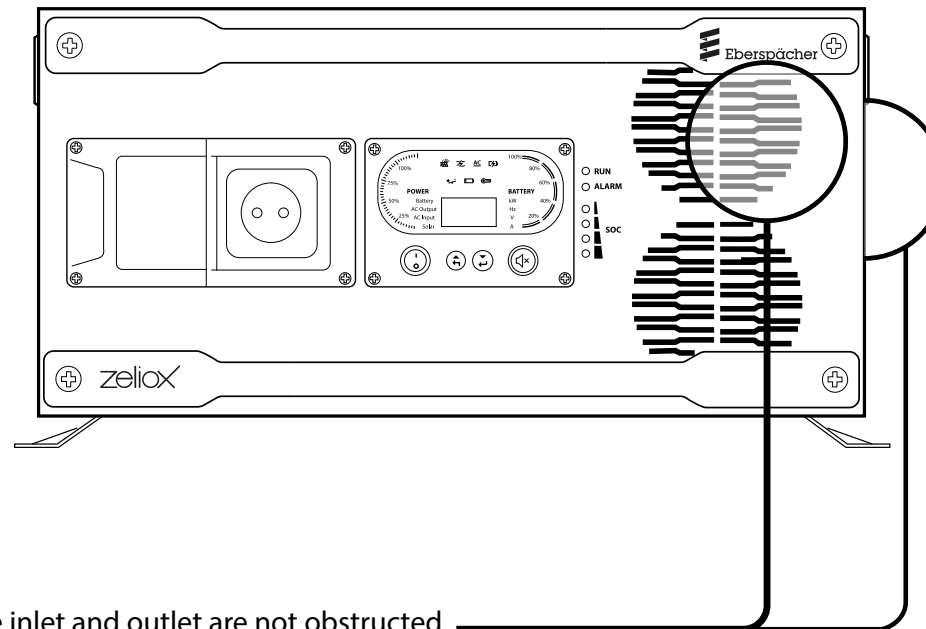

Make sure the inlet and outlet are not obstructed

10. In case of an Alarm

First look into the Zeliox ECO App to see what happened.

- Icon yellow warning triangle: Clicking will show the most recent alarm message.
- Icon Gear: Click and select "Events" for the full message history.

Still don't know what to do? Contact your installer or dealer.

Please note: when contacting your installer be sure you have the **s/n serial number** of the Zeliox ECO.



only with model B

with model A and B

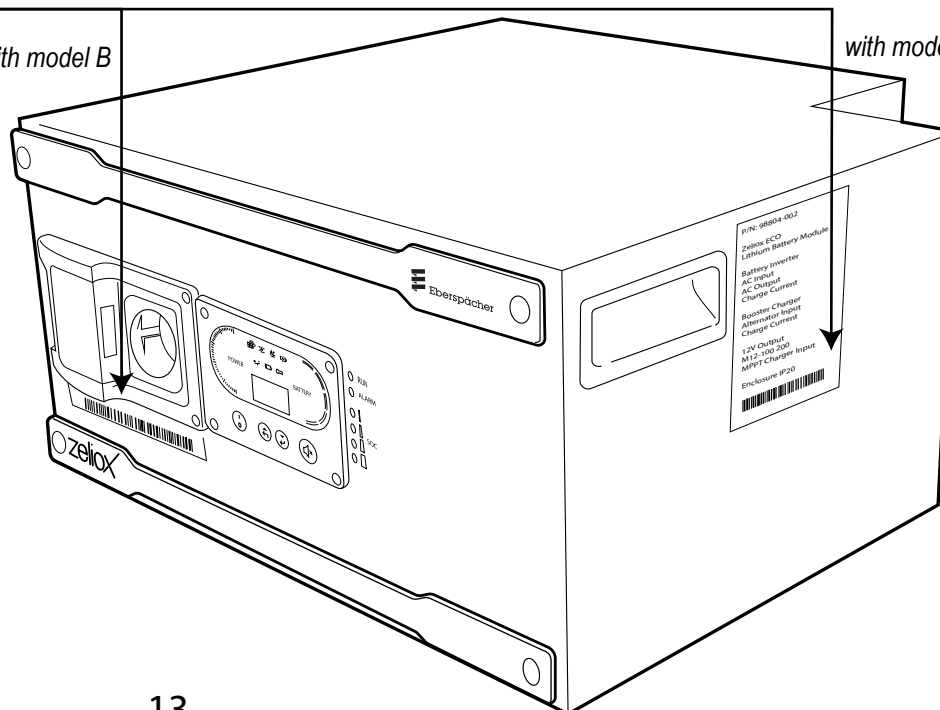

11. Compatible products

We have several products in our range that you can use to expand the ZelioX ECO system. All products have been extensively tested for quality and service life. They can be seamlessly connected to your ECO.

Solar Mate - SF100-30 (Art: ZEL-07-016)

Solar Mate - SF100-50 (Art: ZEL-07-017)

Solar Mate is a solar charge controller with built in Maximum Power Point Tracking (MPPT) technology, which can optimize the PV's output eliminate the fluctuation due to shading or temperatures variables. It tracked the maximum power point of a PV array to deliver the maximum charging current for battery, enabling PV array to increase the output by as much as 30% compared with PWM design.

- Maximum MPPT efficiency up to 99.9%.
- Maximum efficiency up to 98.2%.
- Excellent performance at sunrise and low solar insolation levels.
- High reliability with electronic protections.
- Wide MPPT operating voltage range.
- Forced charge mode.

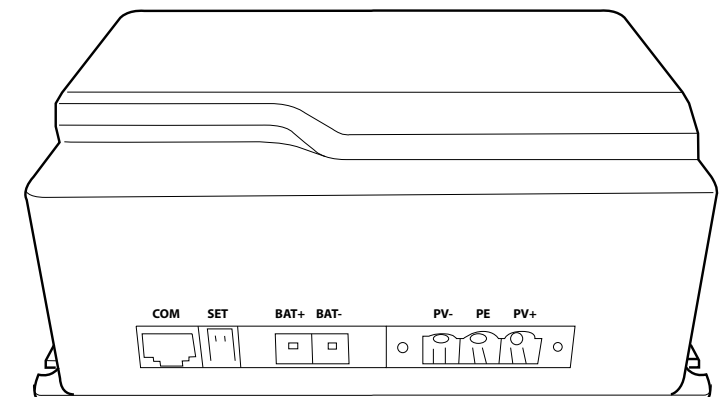
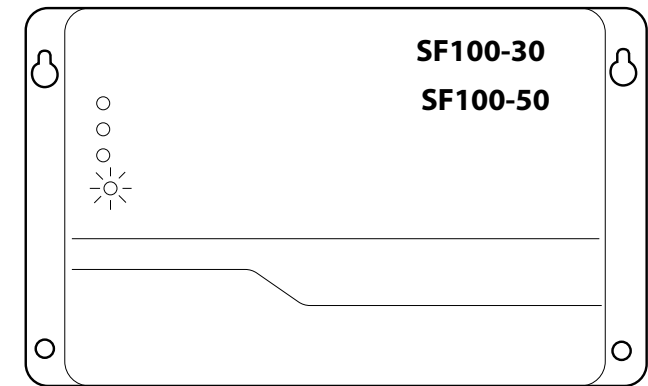

Extended Battery Pack M12-100 (Art. ZEL-ECO-BP-I) Extended Battery Pack M12-200 (Art. ZEL-ECO-BP-II)

The M12 series is a 12V lithium-ion battery module. It configures high-performance and high-reliability BMS to effectively manage the cells, including cell over-voltage, under-voltage, charge over-current, discharge over-current, over-temperature, low temperature, short circuit and other protection functions. It also has built-in cell voltage balance, capacity calculation, SOC calculation, cycle life accumulation and low temperature heating functions.

- Long cycle life, over 3000 cycles at 100% DoD @25°C.
- Supports max discharge current 200A for M12-100 and 300A for M12-200.
- Built-in BMS with automatic balancing and complete protection.
- Built-in high precision ($\pm 0.1A$) shunt for SOC calculation.
- Built-in heater element to support battery being charged at minus temperatures.
- Up to seven additional batteries can be connected to a Zeliox ECO.
- Plug & Play connection with all Zeliox ECO models.
- Make sure to extend the system in the same capacity as present in the Zeliox ECO (see also drawing below).

ECO I / II

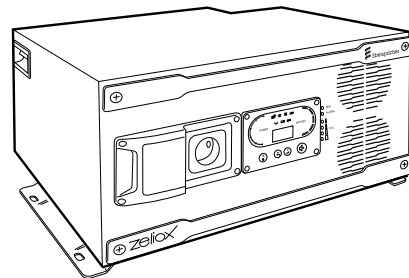

1.3kWh +

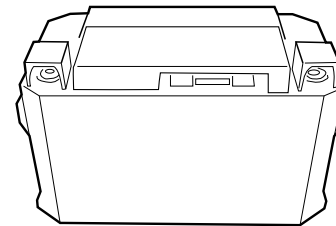

1.3kWh = **2.6kWh**

ECO II+ / III

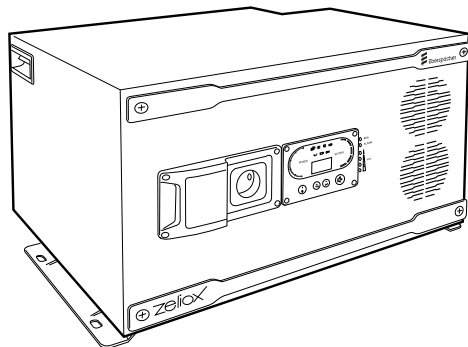

2.6kWh +

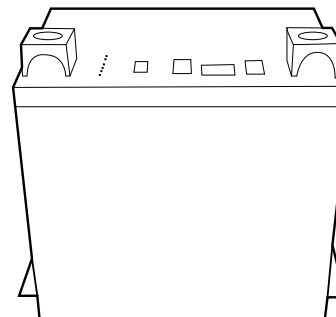

2.6kWh = **5.2kWh**

Remote switch ON/OFF (Art. ZEL-08-015)

With the remote switch, placed on the dashboard, the Zeliox ECO can be switched on and off.

Please note: when using the remote switch, the on/off button at the ECO should remain switched off.

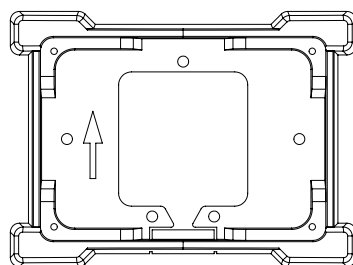
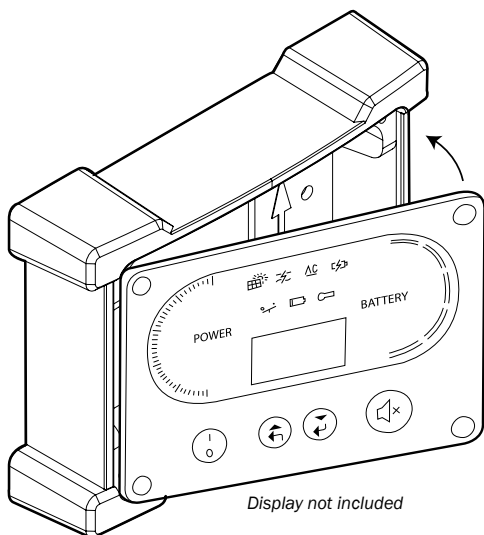
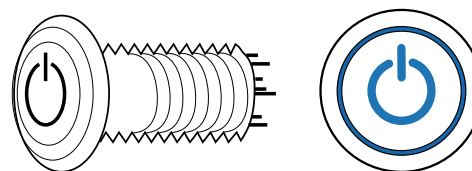

Flushmount adapter for ECO display (Art. ZEL-OPT-027)

With the flushmount adapter, the ECO display can be placed on any other flat surface in the vehicle, for example a cabinet or wall.

The display can be unscrewed from the ECO. A replacement display is needed to close the remaining cavity in the ECO.

The flushmount can be glued or taped or screwed on the surface.

Cover plate with 3m cable (Art. ZEL-OPT-023)

This plate will cover up the opening in the Zeliox, when the display is dismantled. The set also contains a 3m UTP cable to reconnect the display with the Zeliox.

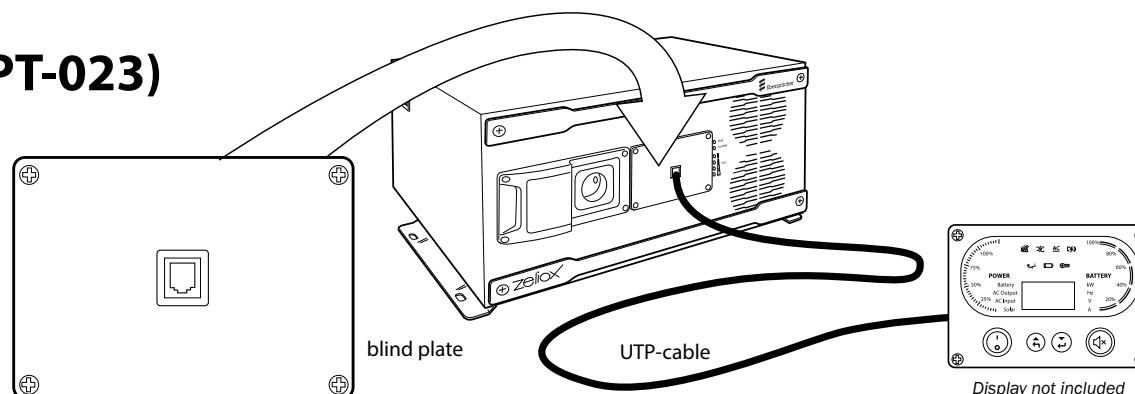

12. TECHNICAL SPECIFICATIONS:

ECO I / II

ECO II+ / III

Summary	ZeliOX ECO I	ZeliOX ECO II	ZeliOX ECO II+	ZeliOX ECO III
Power	1600W	2000W	2000W	3000W
Battery	1.3kWh-100Ah / Heat package / Battery expandable		2.6kWh-200Ah / Heat package / Battery expandable	
Outputs	1x 230V (front) 1x 230V (rear) 1x 12V (rear)			
Charging options	Alternator EV Solar Power Grid Power			
Features	Automatic ECO mode if no power consumption (adjustable) Power control function Power Control			
Safety	Isolation guard Ground fault and overcurrent protection Battery management system			
Interface	IOS-Android APP Bluetooth Movable LED Display Dashboard switch (optional)			
Warranty	5-year hardware and battery warranty			
Battery	ZeliOX ECO I	ZeliOX ECO II	ZeliOX ECO II+	ZeliOX ECO III
Capacity	1,3kWh		2,6kWh	
Current	100Ah		200Ah	
Type	Lithium 12,8V			
Composition	LiFePO4			
Self-discharge	Less than 3% per month			
Protection	Heat pack for charging at low temperatures			
Type of expansion battery	12.8V-100Ah Discharge cont. 100A Maximized 120A		12.8V-100Ah Discharge cont. 100A Maximized 120A	
Output	ZeliOX ECO I	ZeliOX ECO II	ZeliOX ECO II+	ZeliOX ECO III
AC 230V Voltage	230V AC			
AC 230V Frequency	50/60Hz			
AC 230V Ampere limit	C16A			
AC 230V Continuous	1600W	2000W		3000W
AC 230V 10 min	1700W	2150W		3200W
AC 230V 10 sec peak	1700W	2150W		3200W
AC 230V Overvoltage peak	3200W	4000W		6000W
AC 230V ECO mode	Automatic ECO mode if no consumption is detected (adjustable in Watts and Duration)			
DC 12V Voltage	11,6-14,2V DC		11,2-14,2V DC	
DC 12V Ampere limit	50 A Limited by connector			
DC 12V Continuous	580-710W		560-710W	

12. TECHNICAL SPECIFICATIONS:

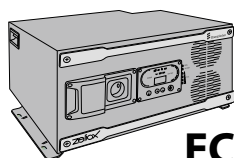

ECO I / II

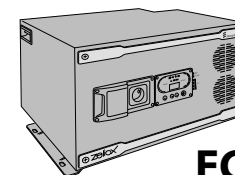

ECO II+ / III

Entrance	ZeliOX ECO I	ZeliOX ECO II	ZeliOX ECO II+	ZeliOX ECO III
AC 230V Voltage	175-265V			
AC 230V Frequency	45-65Hz			
AC 230V Charging power	60A-850W	60A-850W	100A-1400W	120A-1700W
AC 230V Power Control	Gives priority to consumer Remaining capacity is available for battery charging			
DC 12V Voltage	12-16V DC			
DC 12V Continuous Power DC	30A		60A	
DC 12V Charge Power MPPT	50ADC Maximized by connector			
Connections (plugs included)	ZeliOX ECO I	ZeliOX ECO II	ZeliOX ECO II+	ZeliOX ECO III
AC 230V Mains input	ZeliOX power cable Schuko-IEC			
AC 230V Output	1x Schuko (front) / 1x IEC (rear)			
DC 12V Starter battery input	SA50A Red (rear)			
DC 12V Solar energy input	SA50A Blue (rear)			
DC 12V Input Battery Expansion	SA120A Gray (rear)		SA175A Gray (rear)	
DC 12V Output	SA50A Gray (rear)			
Product Information	ZeliOX ECO I	ZeliOX ECO II	ZeliOX ECO II+	ZeliOX ECO III
Product weight	33 kg	35 kg	51 kg	54 kg
Weight including packaging	36 kg	38 kg	55 kg	58 kg
Product dimensions	W450 H225 D392 (mm)		W520 H303 D392 (mm)	
Package dimensions	W525 H305 D485 (mm)		W595 H385 D485 (mm)	
IP rating	IP20			
Temperature range	-20 to +60°C			
Operation consumption	15W			
Sleep Mode Consumption	Less than 0.1 mA			
Cooling	Dual fans - forced air			

13. Zeliox APP | User functions & settings

13.1 User functions: Battery

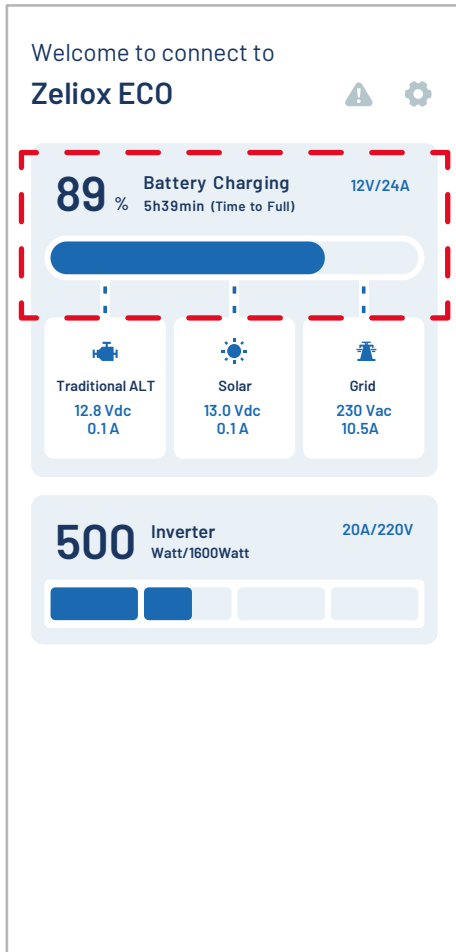

The marked area shows the real life battery information. Click on it for more detailed battery information.

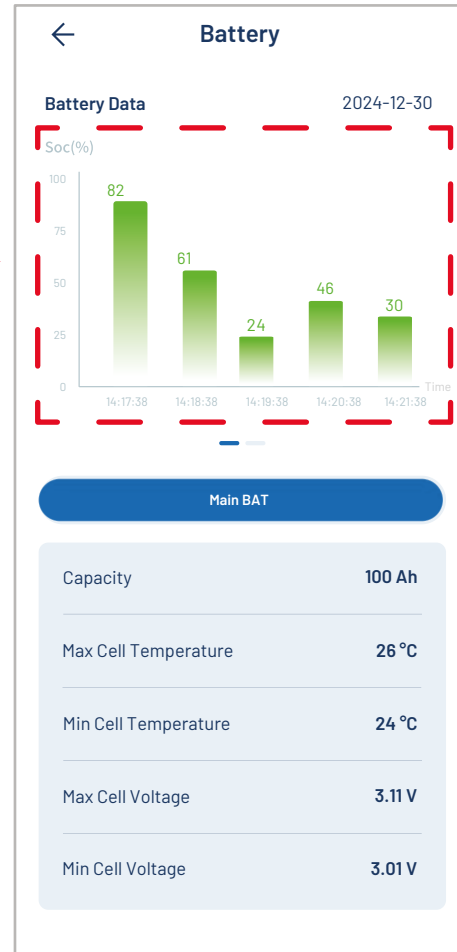

This page gives more details on the battery environment. For more information about the battery swipe left on the marked area

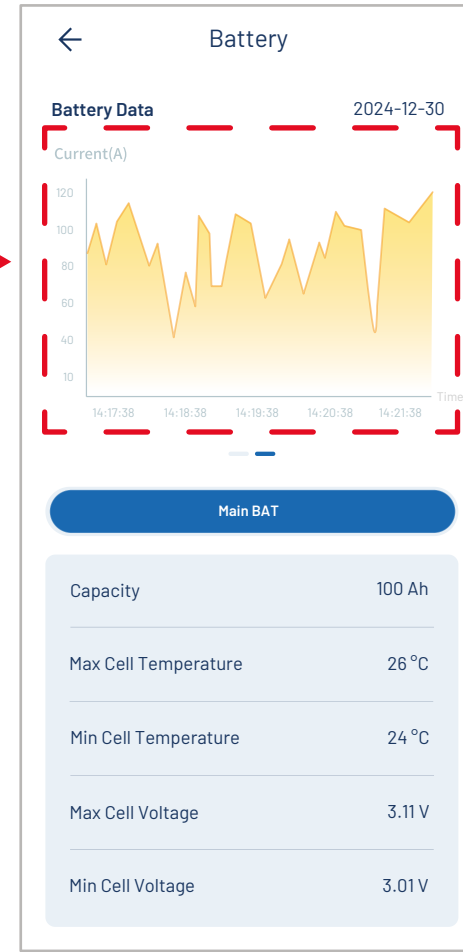

The graph shows the history of the amperage. If you have expanded batteries, you can view only 3 batteries at a time, including the Zeliox.

13. Zeliox APP | User settings

13.2 User functions: Charging

13.3 User functions: Consumption 230V

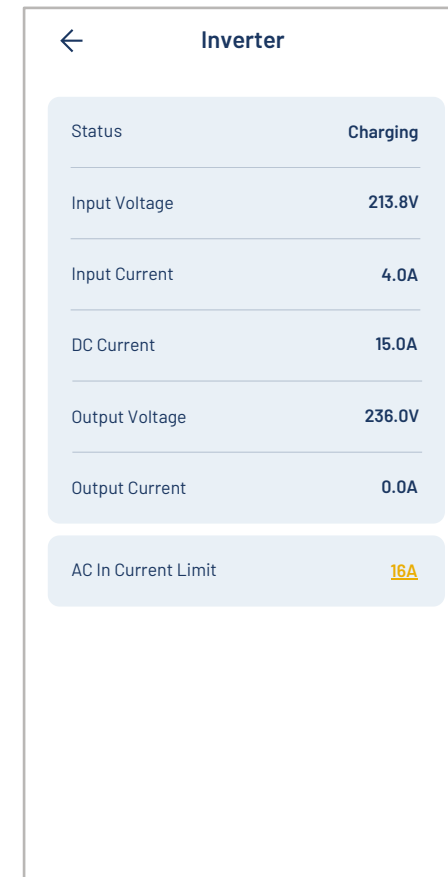
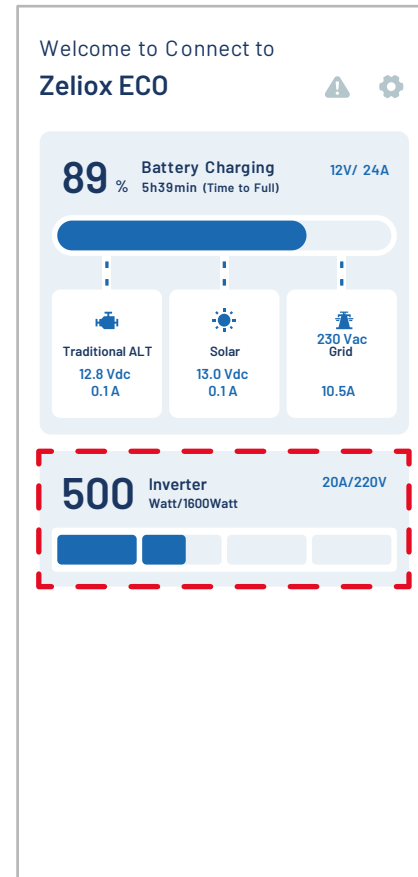
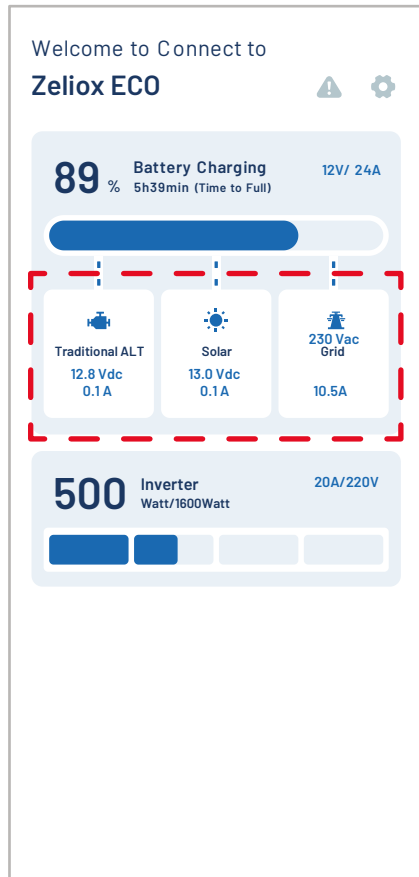

The marked area shows the real life information on the charging source. A blue dotted line towards the battery area marks that this charging method is active.

The marked area shows the real life information on connected 230V loads. Click on it for more information.

More detailed information on the connected load(s).

13. Zeliox APP | User settings

13.4 User settings

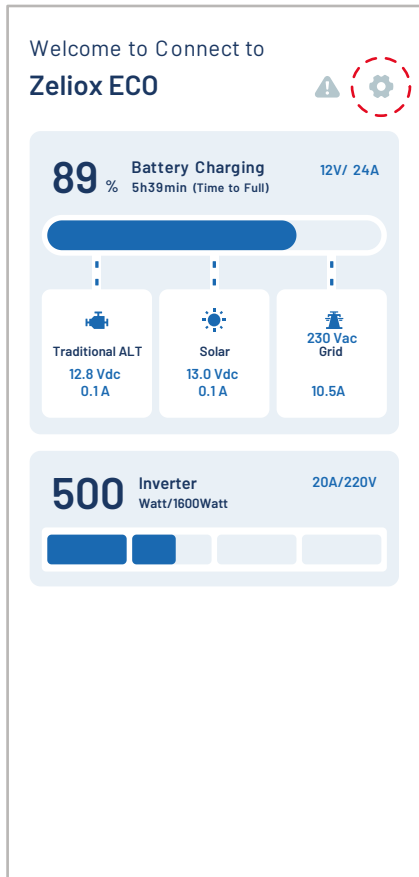

Click on the settings icon.

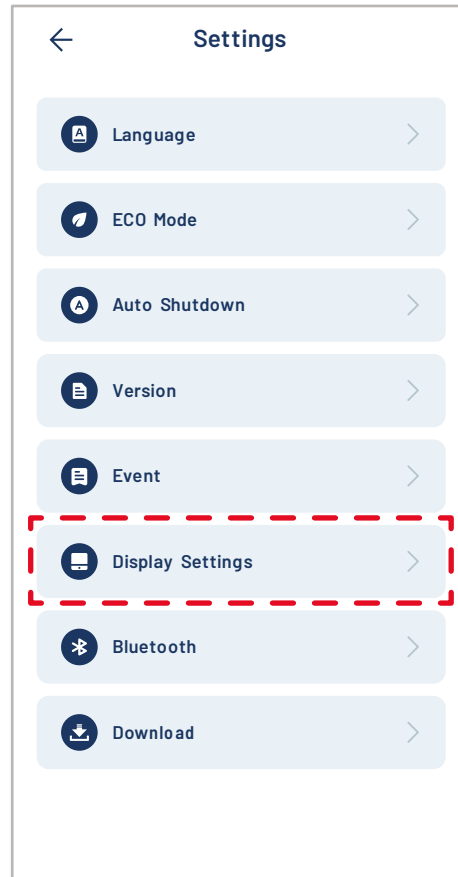

Click on one of the menu buttons for more information.

Silent Mode

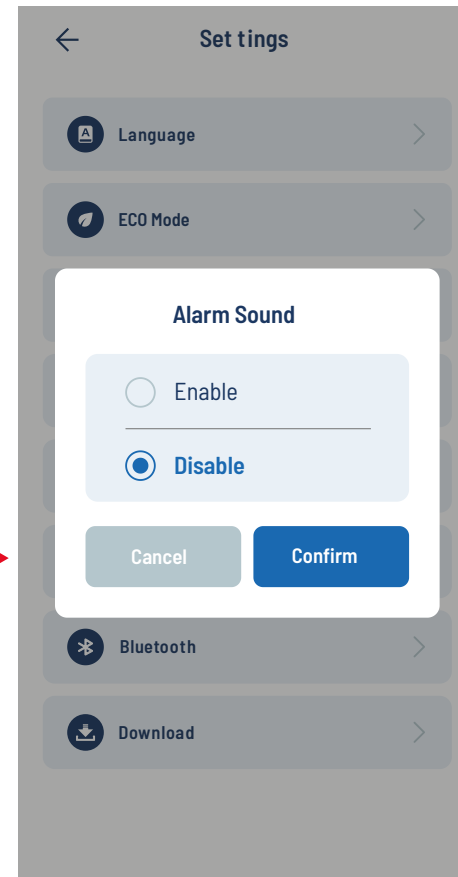

Silent Mode gives the option to switch ON/OFF the low battery alarm.

13. Zeliox APP | User settings

Version



Version gives information relevant version parameters and on Software updates (marked orange). Click on it to update. Please keep phone near to the unit when updating. Don't interrupt the updating process!



Click Confirm to start the software update. Please note: Some updates can take up to 15 - 30 minutes!

Event

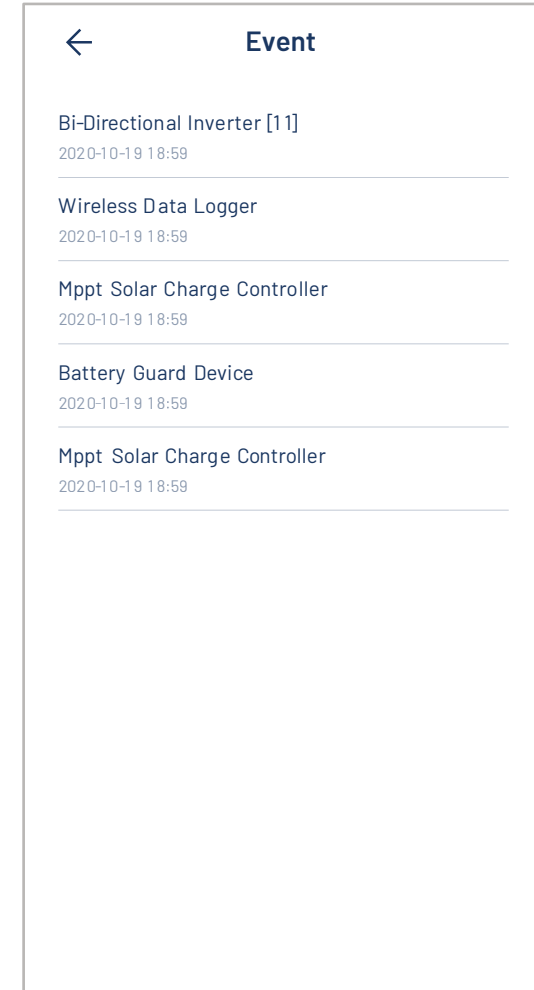

Event will give a full history on all activities since the device has left the factory.

13. Zeliox APP | User settings

Bluetooth

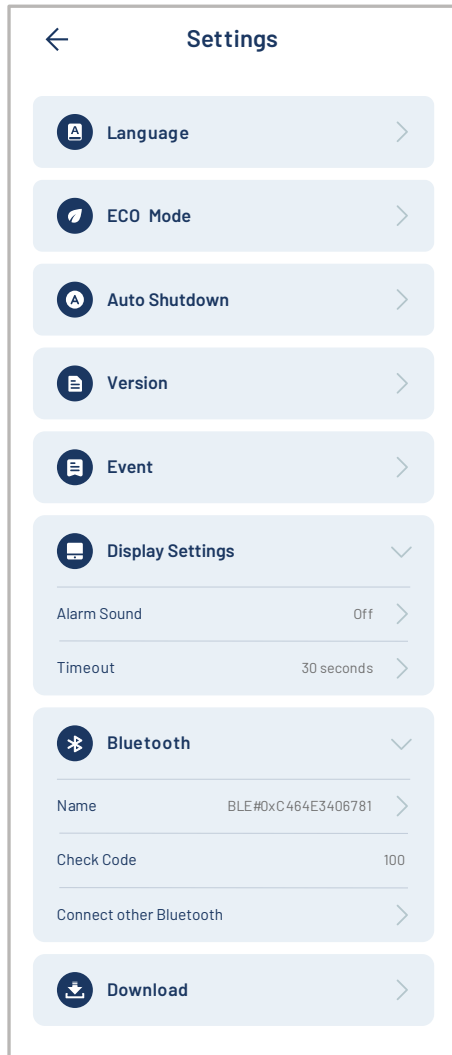

Bluetooth gives details on the current connection between the cell phone and the Zeliox device.

13.5 Insulation error combined with delayed AC shutdown

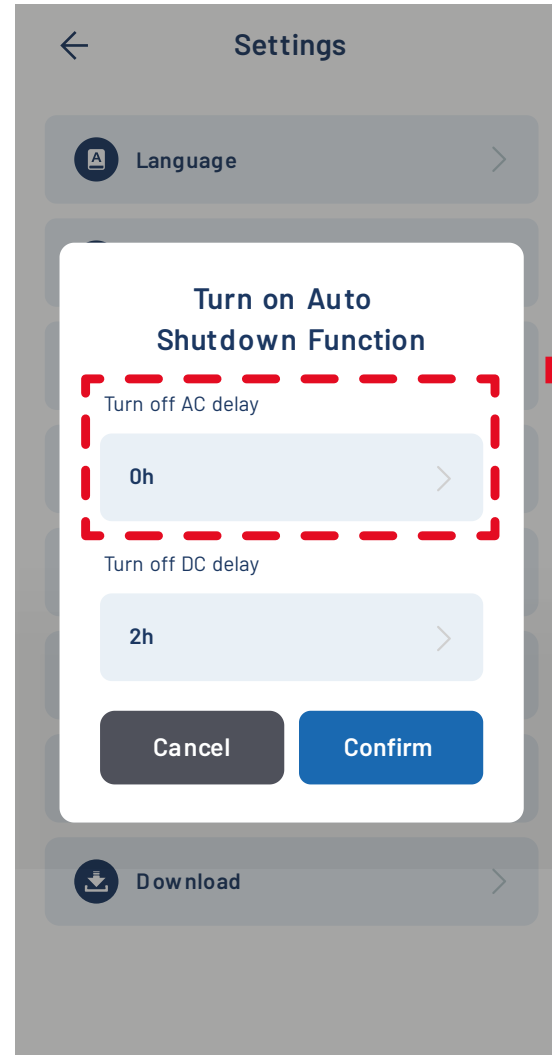

This is a screenshot from the engineering menu, which is accessible by your installer only.

This information is only important if your installer has a delayed auto shut off for the 230V outlets.

Should an insulation error occur within the delayed timer window, you cannot reset the error quickly without disabling this function.

Follow these steps to reset the system:

- 1) Disconnect all 230V devices from the Zeliox.
- 2) Turn off the Zeliox with the main switch.
- 3) Wait until the delayed timer setting has passed. Alternatively you can ask assistance from your installer to turn off the delayed timer setting in the engineering menu (see screenshot).
- 4) After switching on again, the insulation error message should be cleared.
- 5) When you connect your devices again one by one to the Zeliox, you can check where the insulation error has occurred.

14. Disposal or recycle

Disposal and recycling of lithium batteries should comply with local, state, and federal laws and regulations. Mixed treatment with other (industrial) waste is prohibited.

Keep the original packaging, in case of return shipment



Service portal



For more specifications see www.eberspaecher-zeliox.com

Eberspächer Zeliox B.V.
Spaarpot 13
5667 KV Geldrop
The Netherlands